

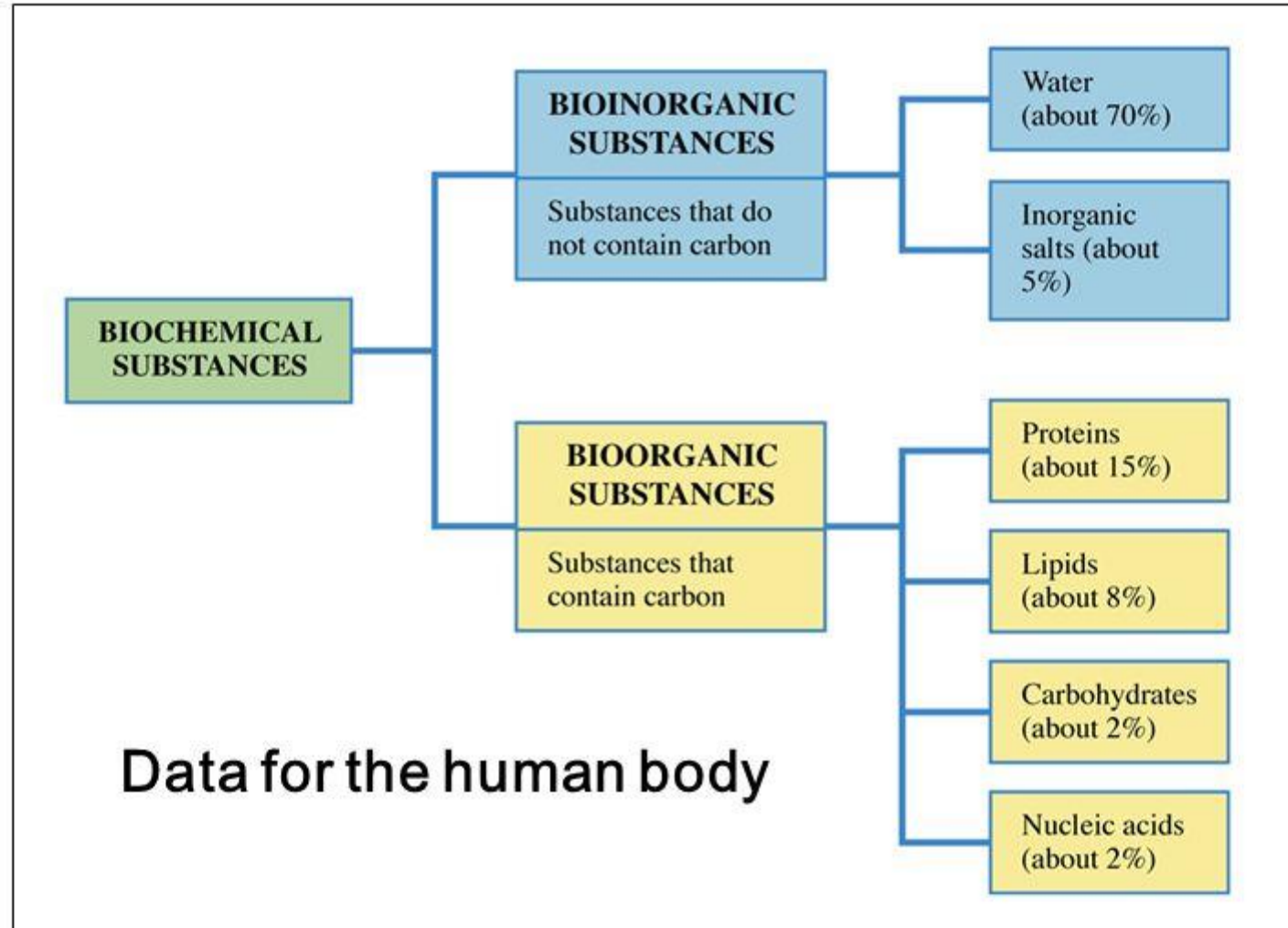



Biomolecules

Mass composition data for the human body in terms of major types of biochemical substances.

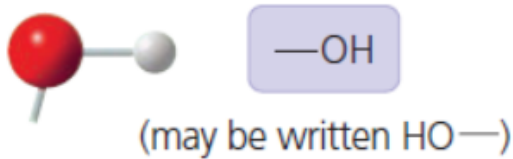
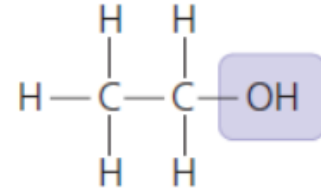
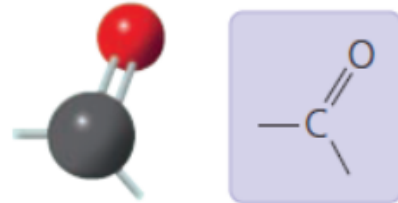
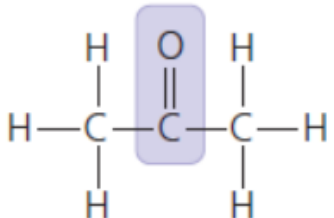
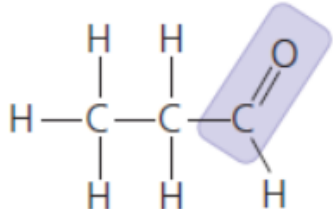
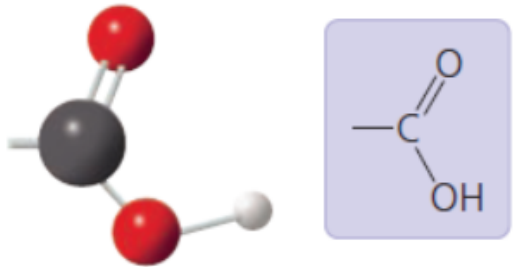
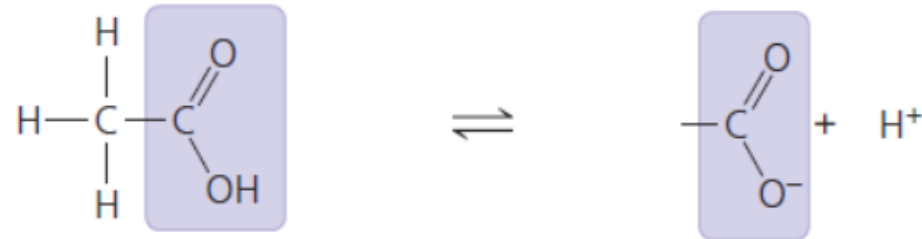

▼ **Figure 4.9** Some biologically important chemical groups.

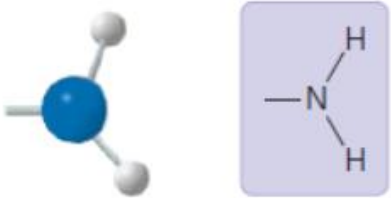
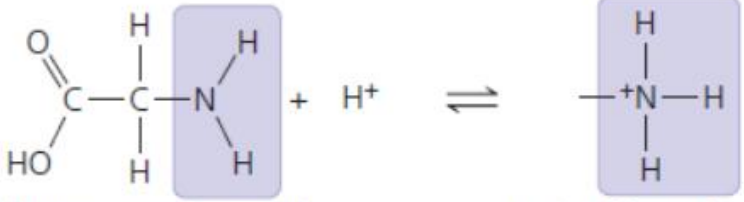
Chemical Group	Group Properties and Compound Name	Examples
<p>Hydroxyl group (—OH)</p>  <p>(may be written HO—)</p>	<p>Is polar due to electronegative oxygen. Forms hydrogen bonds with water, helping dissolve compounds such as sugars.</p> <p>Compound name: Alcohol (specific name usually ends in <i>-ol</i>)</p>	 <p>Ethanol, the alcohol present in alcoholic beverages</p>
<p>Carbonyl group (>C=O)</p> 	<p>Sugars with ketone groups are called ketoses; those with aldehydes are called aldoses.</p> <p>Compound name: Ketone (carbonyl group is within a carbon skeleton) or aldehyde (carbonyl group is at the end of a carbon skeleton)</p>	 <p>Acetone, the simplest ketone</p>  <p>Propanal, an aldehyde</p>
<p>Carboxyl group (—COOH)</p> 	<p>Acts as an acid (can donate H^+) because the covalent bond between oxygen and hydrogen is so polar.</p> <p>Compound name: Carboxylic acid, or organic acid</p>	 <p>Acetic acid, which gives vinegar its sour taste</p> <p>Ionized form of —COOH (carboxylate ion), found in cells</p>

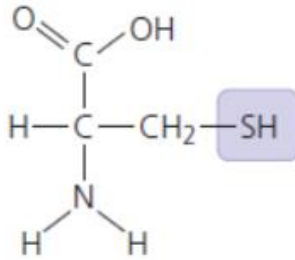
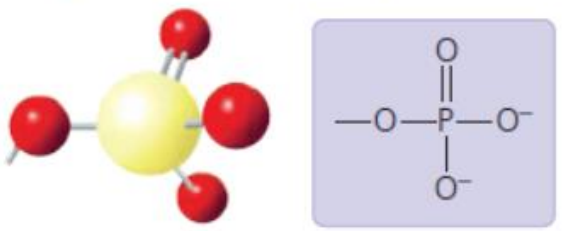
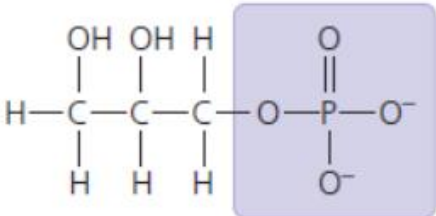
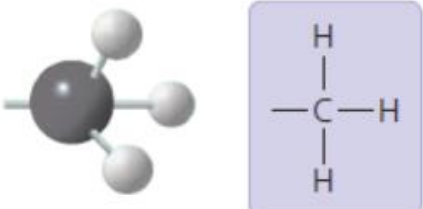
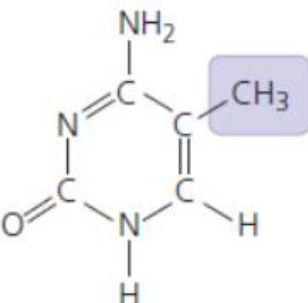
<p>Amino group (—NH_2)</p> 	<p>Acts as a base; can pick up an H^+ from the surrounding solution (water, in living organisms).</p> <p>Compound name: Amine</p>	 <p>Glycine, an amino acid (note its carboxyl group)</p> <p>Ionized form of —NH_2, found in cells</p>
<p>Sulfhydryl group (—SH)</p>  <p>(may be written HS —)</p>	<p>Two —SH groups can react, forming a “cross-link” that helps stabilize protein structure. Hair protein cross-links maintain the straightness or curliness of hair; in hair salons, permanent treatments break cross-links, then re-form them while the hair is in the desired shape.</p> <p>Compound name: Thiol</p>	 <p>Cysteine, a sulfur-containing amino acid</p>
<p>Phosphate group (—OPO_3^{2-})</p> 	<p>Contributes negative charge (1- when positioned inside a chain of phosphates; 2- when at the end). When attached, confers on a molecule the ability to react with water, releasing energy.</p> <p>Compound name: Organic phosphate</p>	 <p>Glycerol phosphate, which takes part in many important chemical reactions in cells</p>
<p>Methyl group (—CH_3)</p> 	<p>Affects the expression of genes when on DNA or on proteins bound to DNA. Affects the shape and function of male and female sex hormones.</p> <p>Compound name: Methylated compound</p>	 <p>5-Methyl cytosine, a component of DNA that has been modified by addition of a methyl group</p>

สารประกอบที่มีสูตรโมเลกุลเหมือนกันอาจมีโครงสร้างที่แตกต่างกันและมีผลทำให้สารประกอบนั้นมีสมบัติต่างกัน

สารประกอบที่เป็นไอโซเมอร์กันอาจมีสมบัติทางฟิสิกส์และเคมีไม่แตกต่างกัน แต่อาจมีชื่อเรียกแตกต่างกัน

โดยทั่วไปจะมีเพียงไอโซเมอร์เดียวที่สามารถแสดงสมบัติทางชีวภาพได้

Isomers

(b) *Cis-trans* isomers

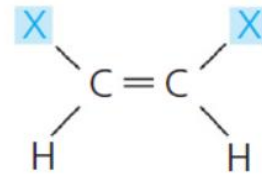

cis isomer: The two Xs are on the same side.

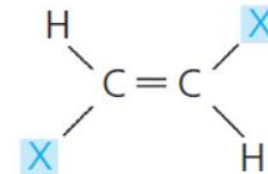

trans isomer: The two Xs are on opposite sides.

Cis-trans isomers differ in arrangement about a double bond. In these diagrams, X represents an atom or group of atoms attached to a double-bonded carbon.

(c) Enantiomers

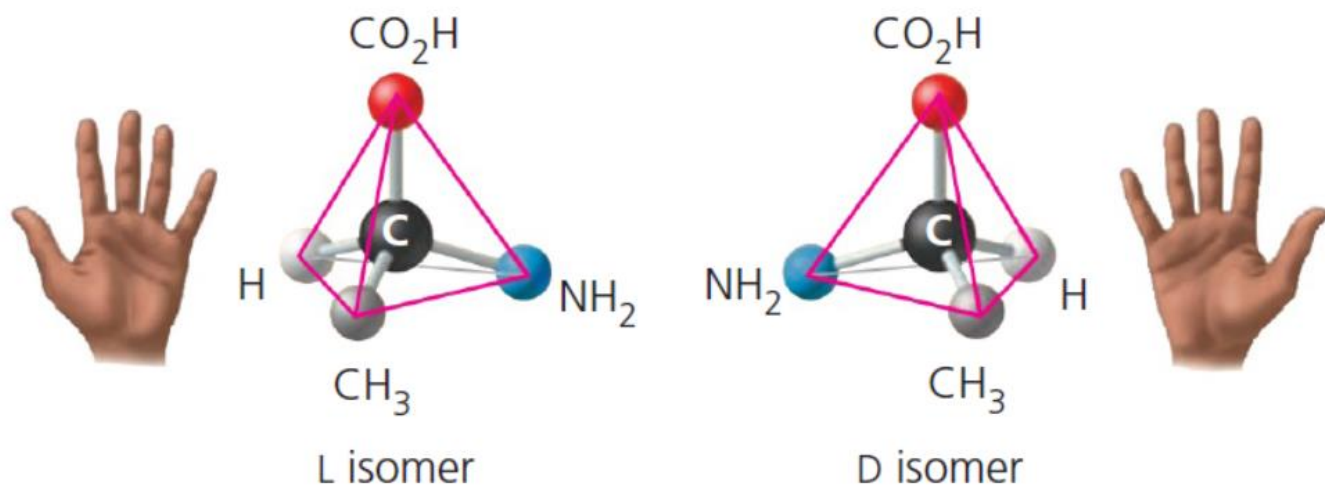

Enantiomers differ in spatial arrangement around an asymmetric carbon, resulting in molecules that are mirror images, like left and right hands. The two isomers here are designated the L and D isomers from the Latin for "left" and "right" (*levo* and *dextro*). Enantiomers cannot be superimposed on each other.

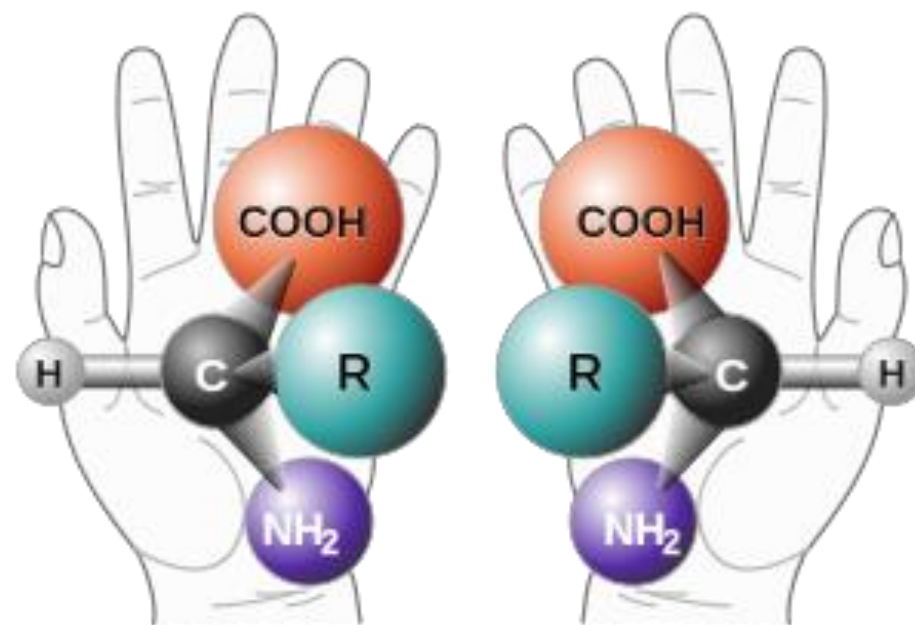

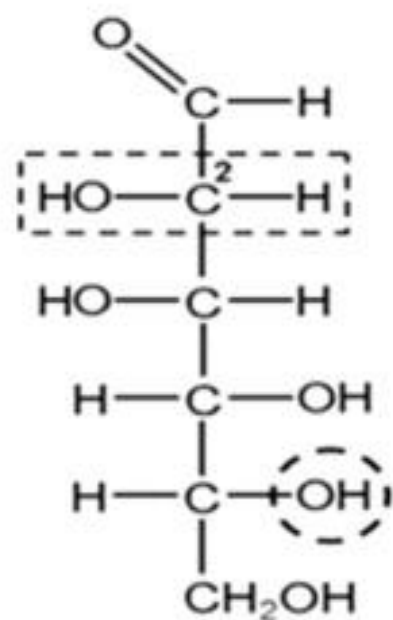

ดี-แมนโนส

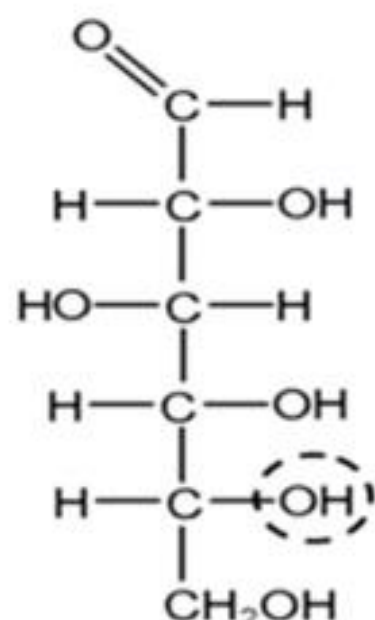

ดี-กลูโคส

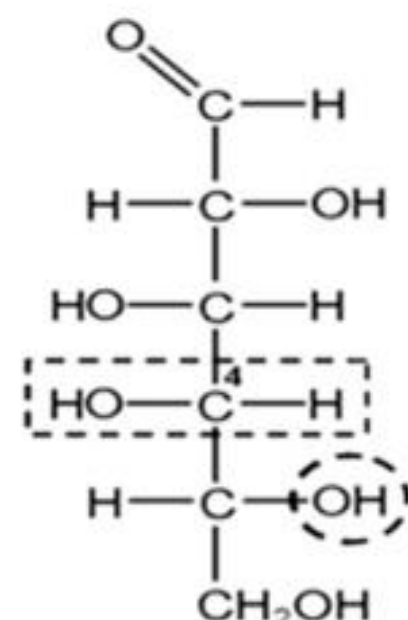

ดี-แกแลกโทส

ตัวอย่างอีพิเมอร์ (epimer) ของมอนแซ็กคาไรด์

Diastereoisomer = isomer ที่ไม่เป็นเงาในกระจกซึ่งกันและกัน เช่น อีพิเมอร์

D- and L- Sugars

For a sugar drawn in the Fischer projection with the most oxidized carbon at the top:

- If the OH on the bottom chiral center points to the **right**, the sugar is **D**
- If the OH on the bottom chiral center points to the **left**, the sugar is **L**

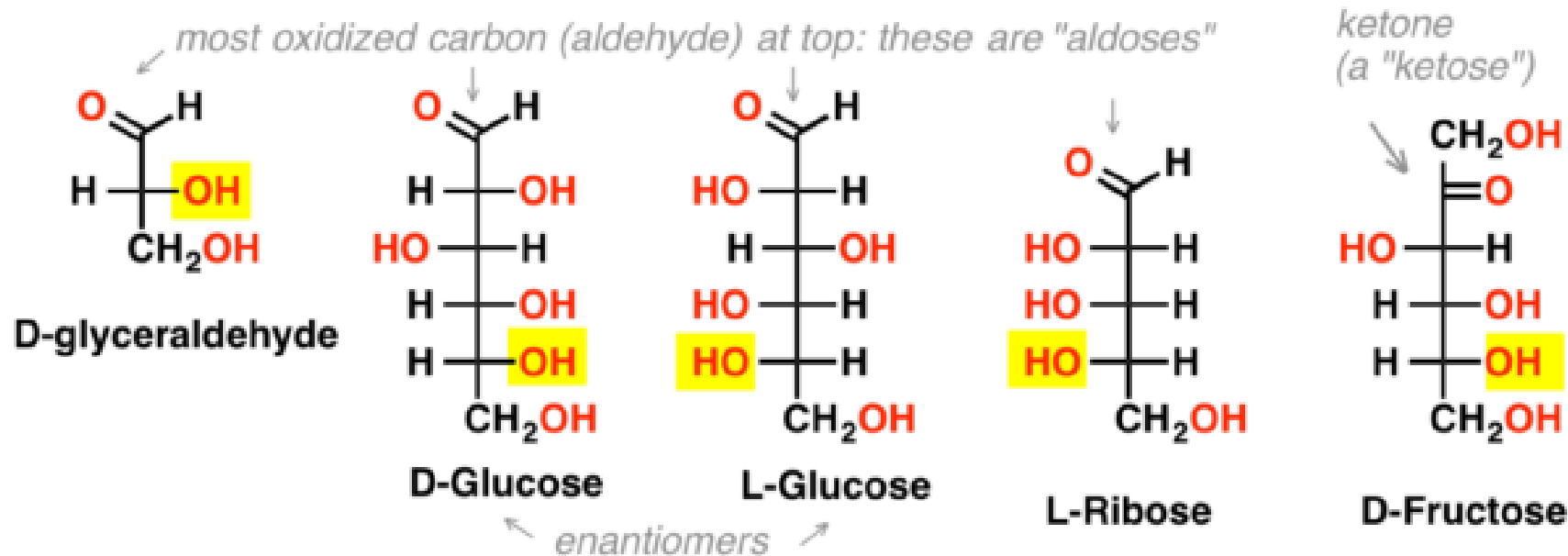

L- and D- is a means of describing the **absolute configuration** of a molecule that pre-dates *R* and *S* but is still used for some biological molecules (sugars, amino acids). It's a quick way of denoting enantiomers: e.g. L-glucose and D-glucose are enantiomers.

L- and D- have no relation to the optical rotation of a molecule.

The D- L- system can also be applied to other chiral molecules, e.g. amino acids:

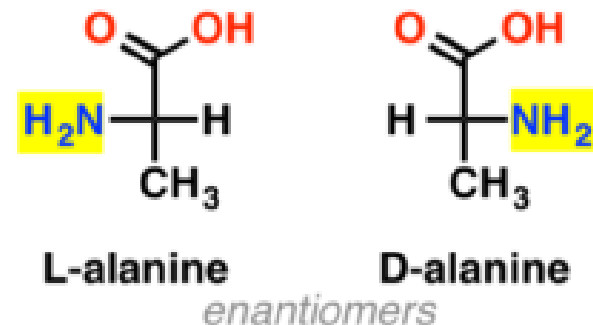

➤ Organic molecules consisting only of **carbon** and **hydrogen** are called ***hydrocarbons***.

➤ Macromolecules are polymers, built from monomers

➤ The Synthesis and Breakdown of Polymers

Figure 5.2a

(a) Dehydration reaction: synthesizing a polymer

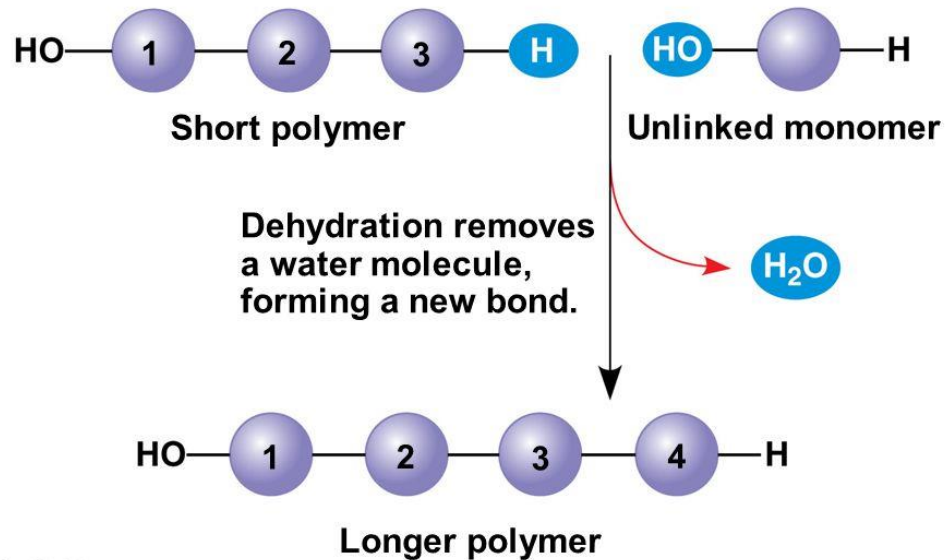
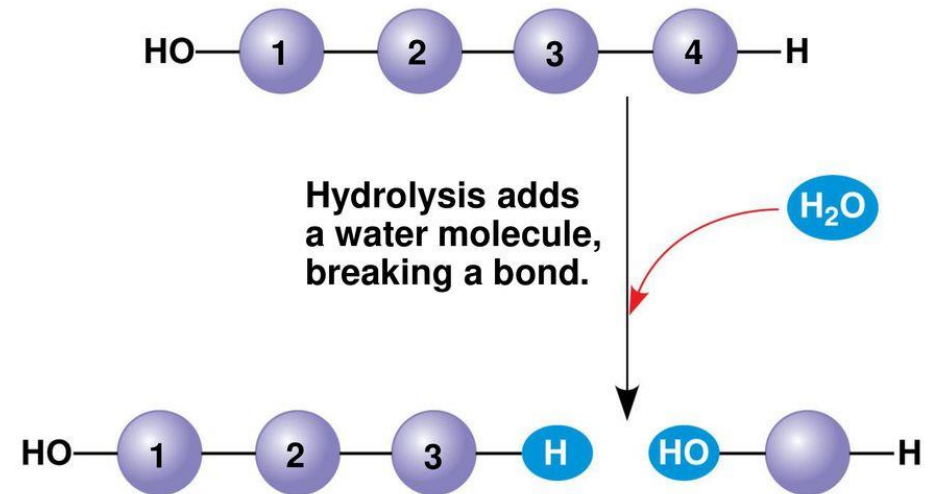

Figure 5.2b

(b) Hydrolysis: breaking down a polymer



Carbohydrates



The **carbohydrates** are a loosely defined group of molecules that contain **carbon, hydrogen, and oxygen** in the molar **ratio 1:2:1**. Their empirical formula is **$(\text{CH}_2\text{O})_n$** , where n is the number of carbon atoms.



The structure and classification of some monosaccharides.

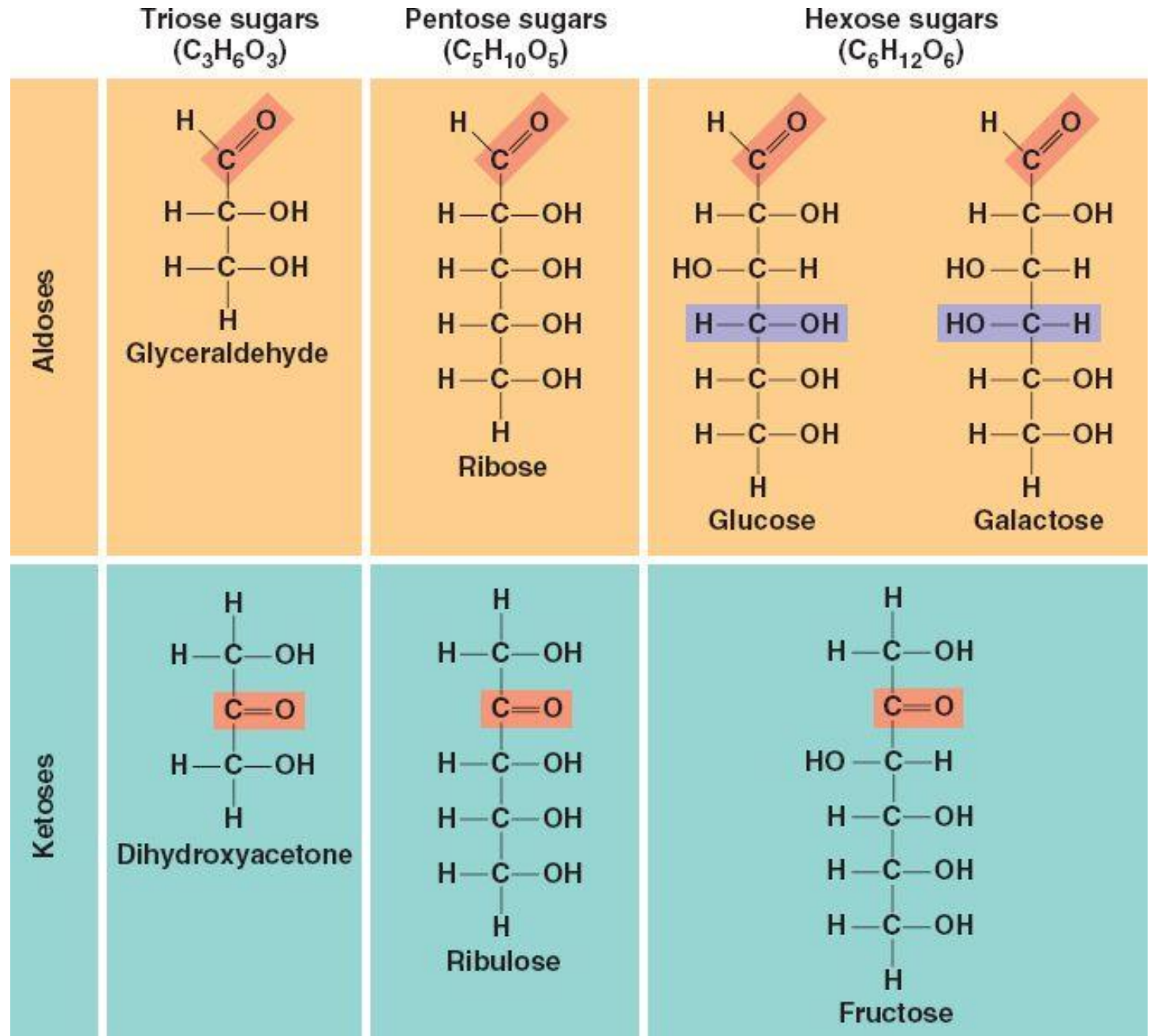

รู้หรือไม่ ?

เพื่อบ่งบอกจำนวนคาร์บอนในโมโนแซ็กคาไรด์ เรามักจะเรียกชื่อตาม **จำนวนคาร์บอน** ที่เป็นองค์ประกอบ โดยมีขั้นตอนการอ่าน ดังนี้

1. อ่านจำนวนคาร์บอนเป็นภาษากรีก

สาม	อ่านว่า ไตร (tri)
สี่	อ่านว่า เตตระ (tetra)
ห้า	อ่านว่า เพนตา (penta)
หก	อ่านว่า เฮกซะ (hexa)
เจ็ด	อ่านว่า เฮปตา (hepta)

2. อ่านลงท้ายเสียง ด้วยคำว่า-โอส (-ose)

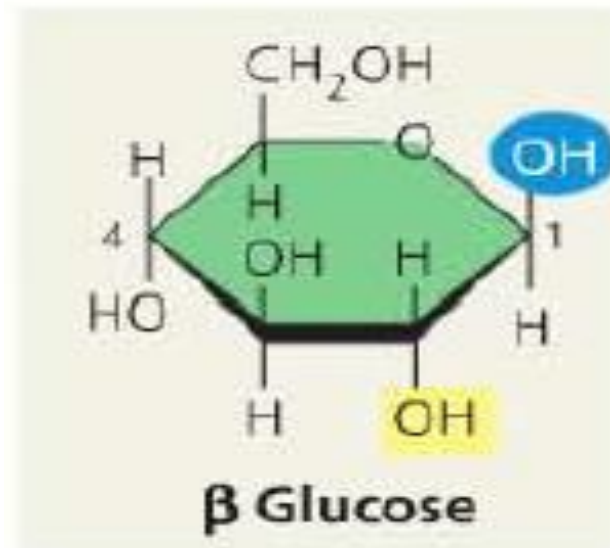

= **Hexose**

จำนวนอะตอม คาร์บอน	ชื่อโมโนแซ็กคาไรด์	สูตรโมเลกุล	ตัวอย่าง
3		C ₃ H ₆ O ₃	
4		C ₄ H ₈ O ₄	
5		C ₅ H ₁₀ O ₅	
6		C ₆ H ₁₂ O ₆	

Carbohydrates



Monosaccharide



Oligosaccharide



Polysaccharide

Monosaccharide

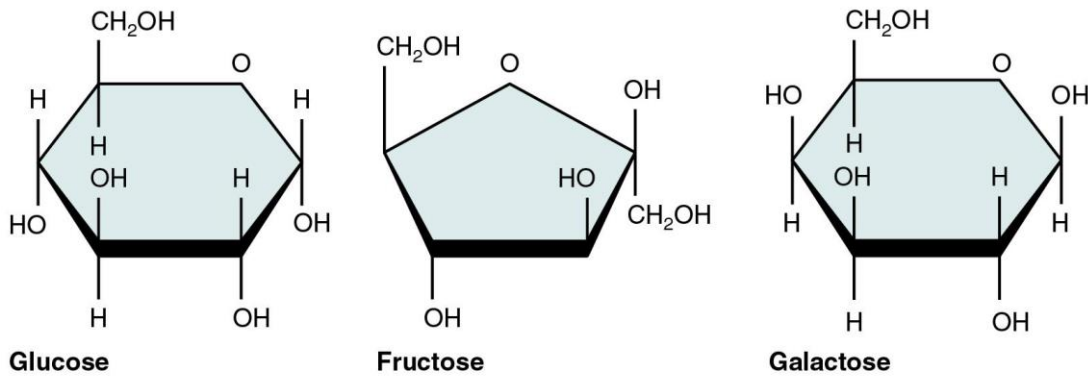

(a) Hexoses

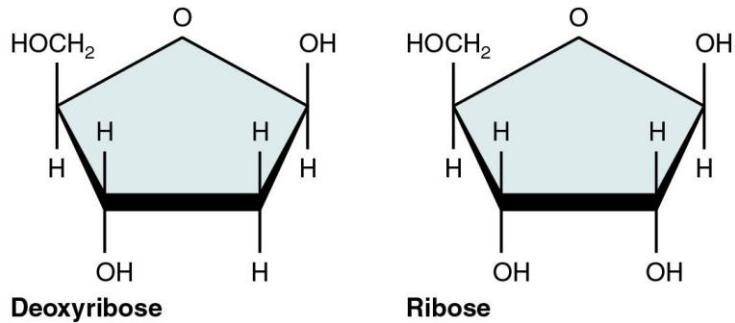

(b) Pentoses

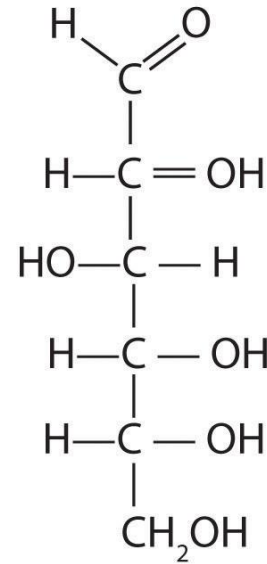

D-(+)-glucose

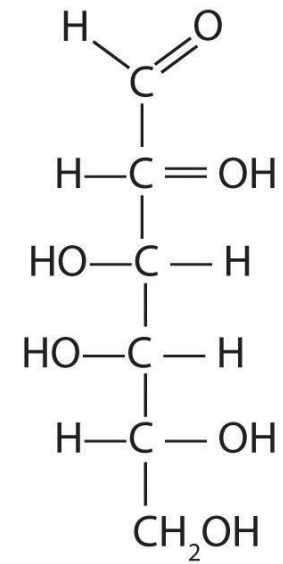

D-(+)-galactose

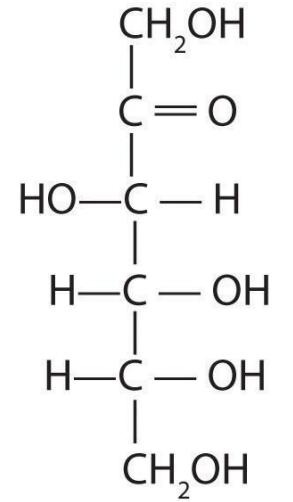

D-(-)-fructose

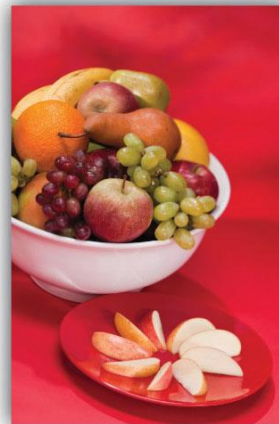

➤ เพิ่มเติม : Linear and ring forms of glucose.

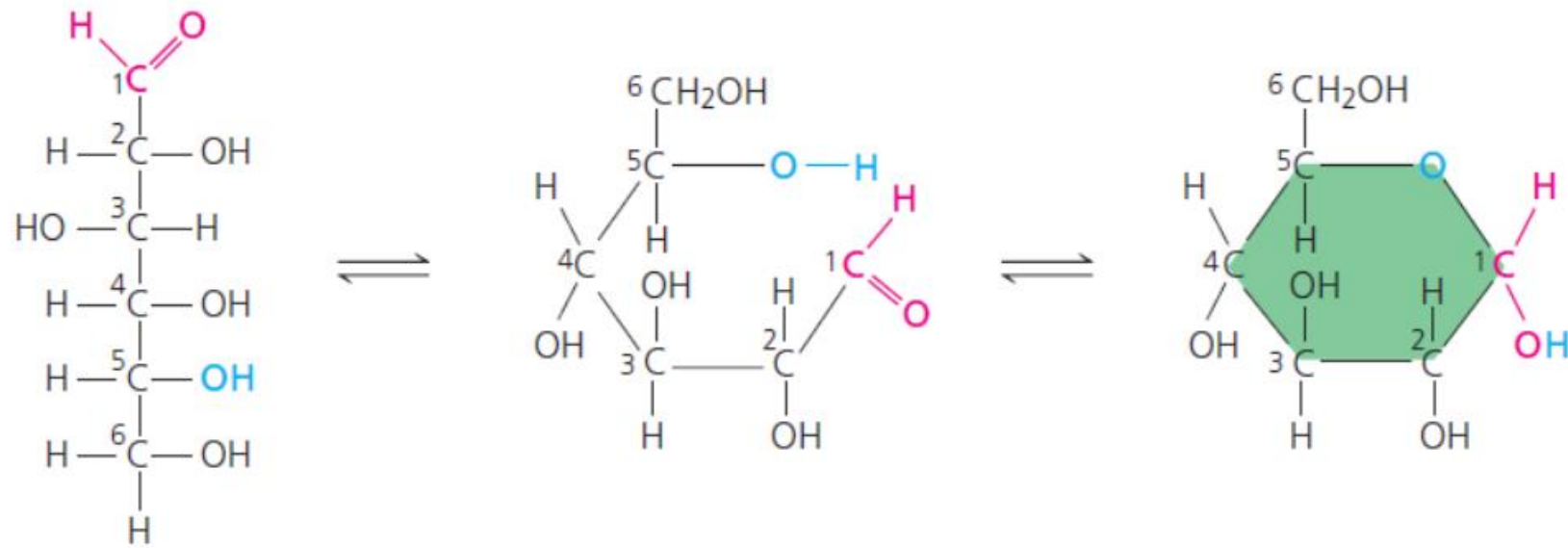

(a) Linear and ring forms. Chemical equilibrium between the linear and ring structures greatly favors the formation of rings. The carbons of the sugar are numbered 1 to 6, as shown. To form the glucose ring, carbon 1 (magenta) bonds to the oxygen (blue) attached to carbon 5.

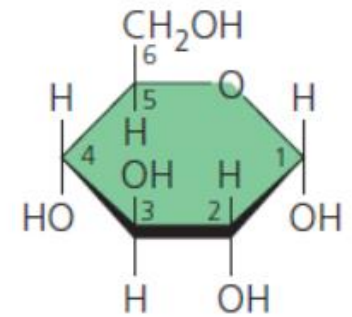

(b) Abbreviated ring structure. Each unlabeled corner represents a carbon. The ring's thicker edge indicates that you are looking at the ring edge-on; the components attached to the ring lie above or below the plane of the ring.

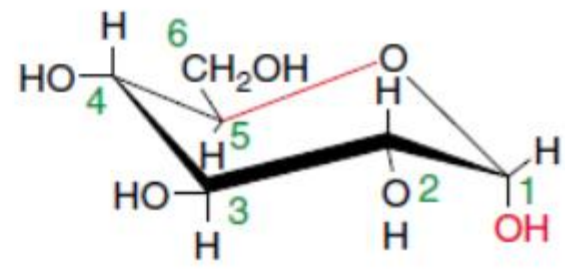
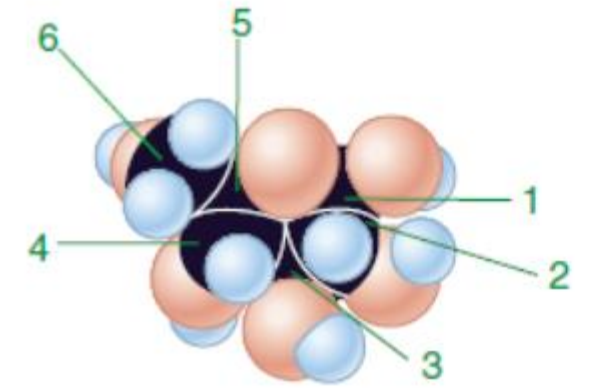
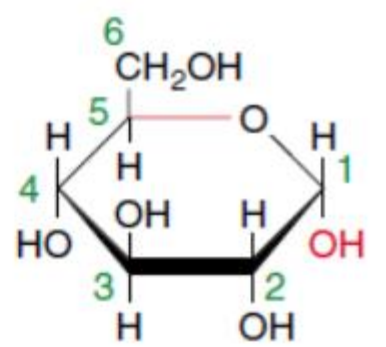
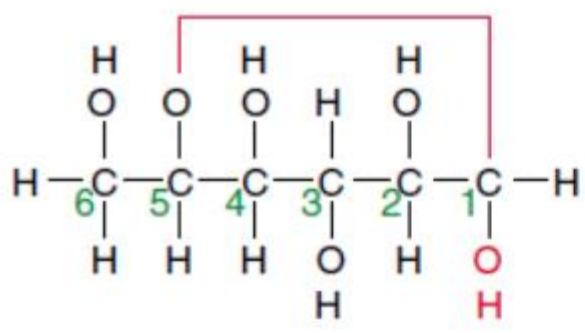
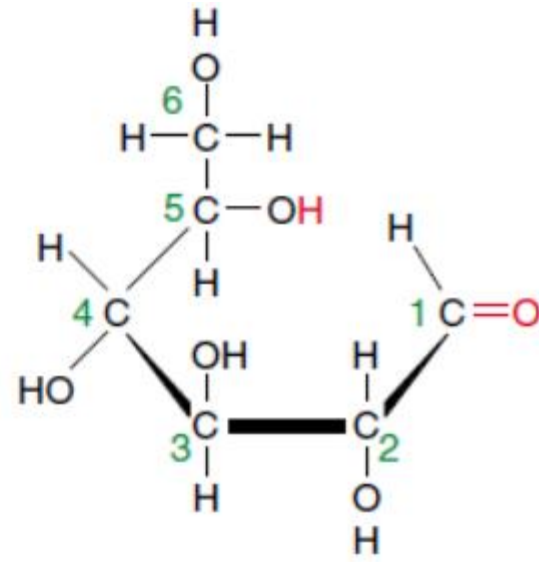
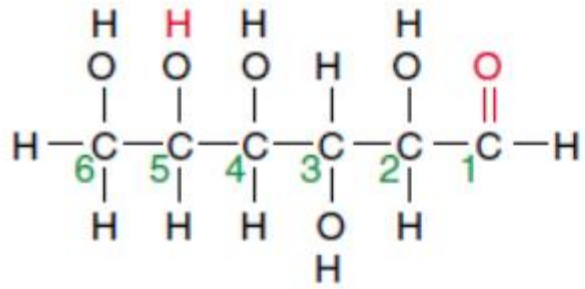

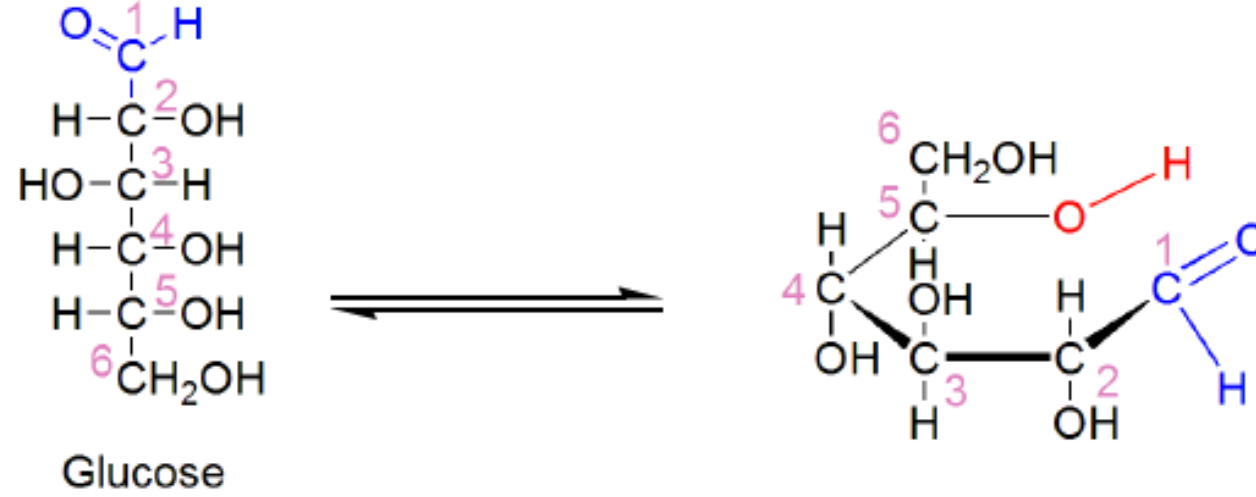

ภาพ Fischer Projection ของกลูโคสและเปิดปิด โครงสร้าง

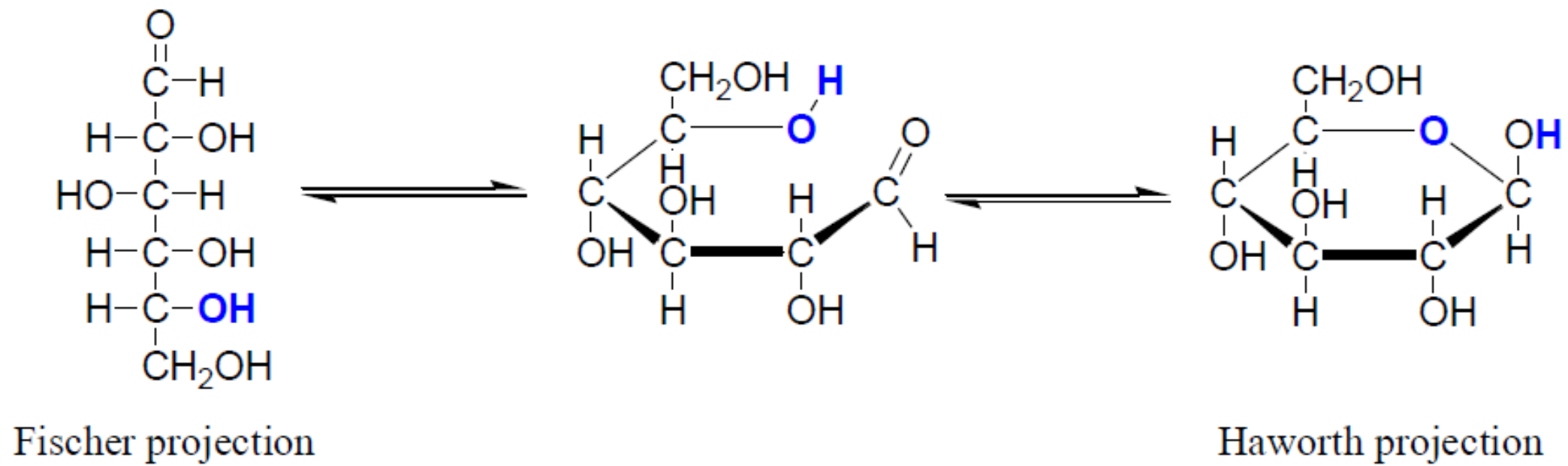

ภาพ การเกิด โครงสร้างแบบวงของกลูโคส

(a) α and β glucose ring structures. These two interconvertible forms of glucose differ in the placement of the hydroxyl group (highlighted in blue) attached to the number 1 carbon.

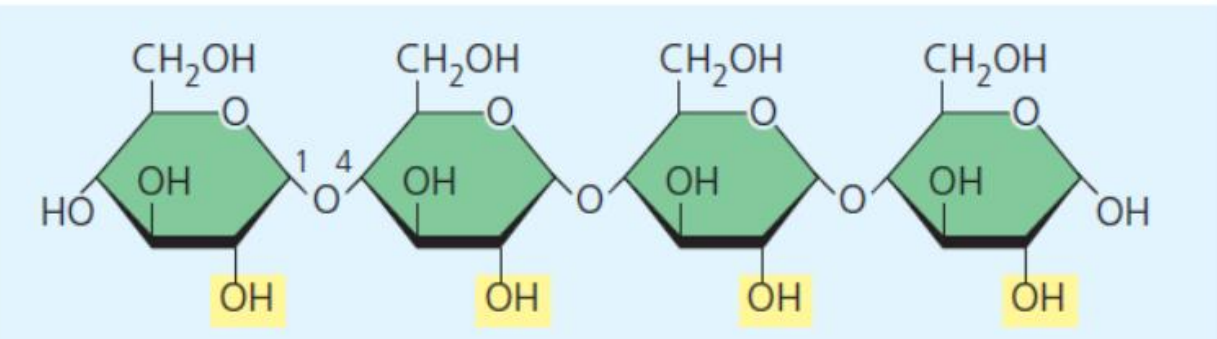
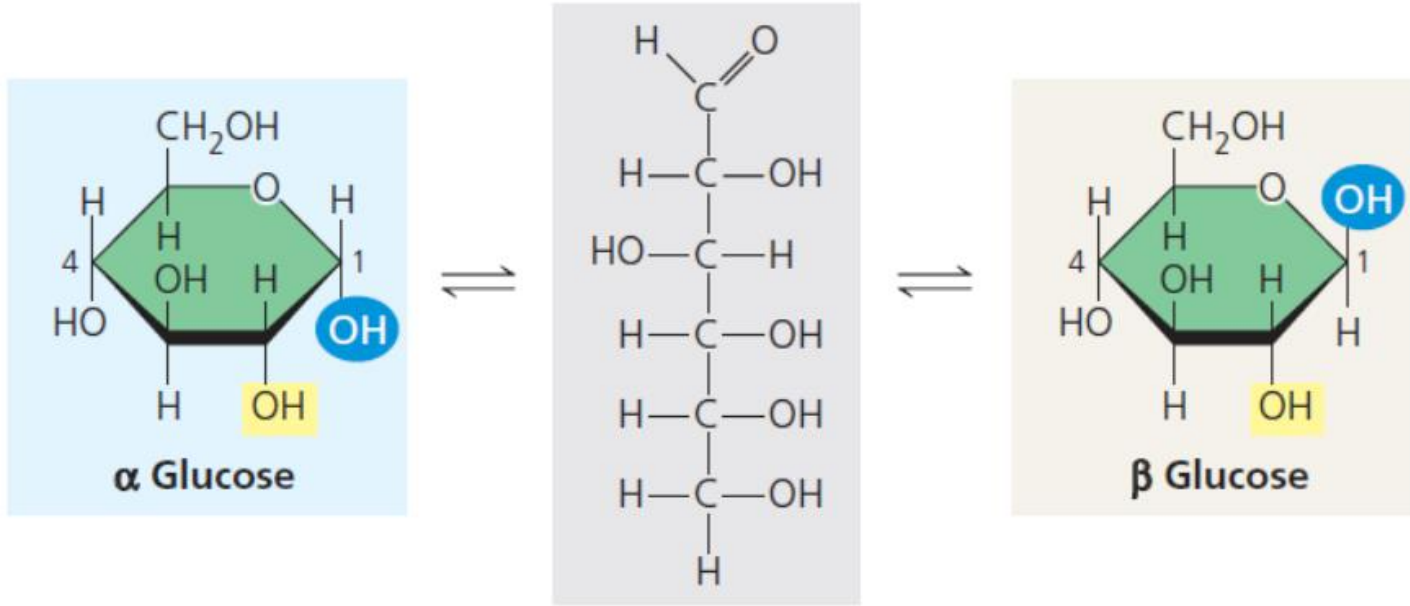

(b) Starch: 1–4 linkage of α glucose monomers. All monomers are in the same orientation. Compare the positions of the —OH groups highlighted in yellow with those in cellulose (c).

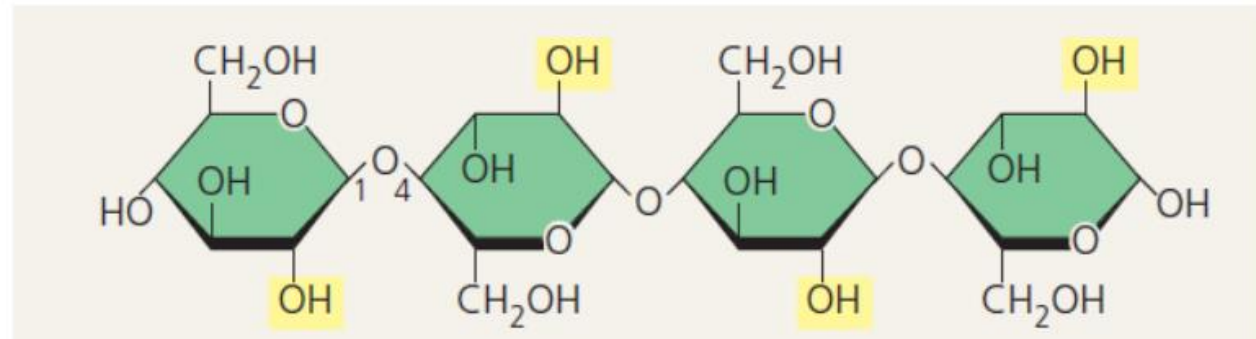

(c) Cellulose: 1–4 linkage of β glucose monomers. In cellulose, every β glucose monomer is upside down with respect to its neighbors. (See the highlighted —OH groups.)

▲ Figure 5.7 Starch and cellulose structures.

Disaccharide

Sucrose
(glucose and fructose)

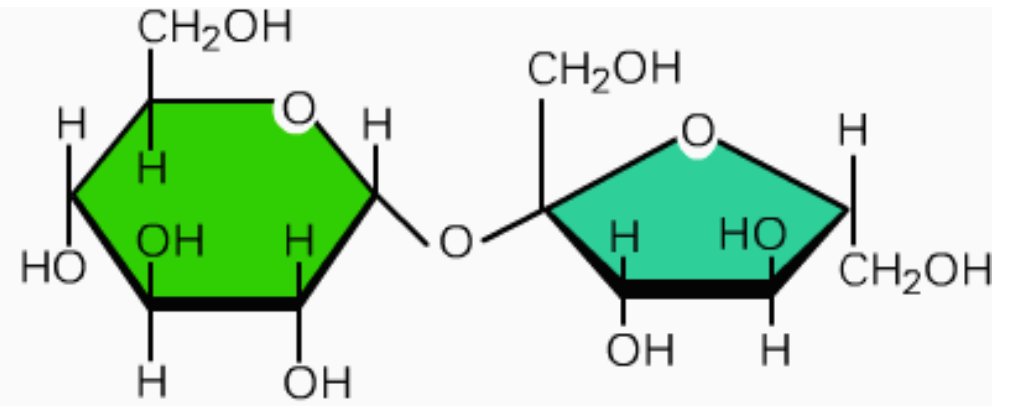

Lactose
(galactose and glucose)

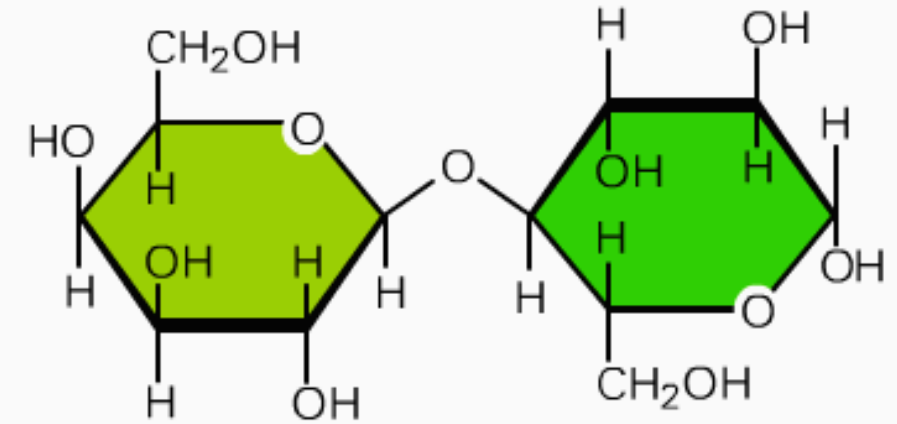

Maltose
(glucose and glucose)

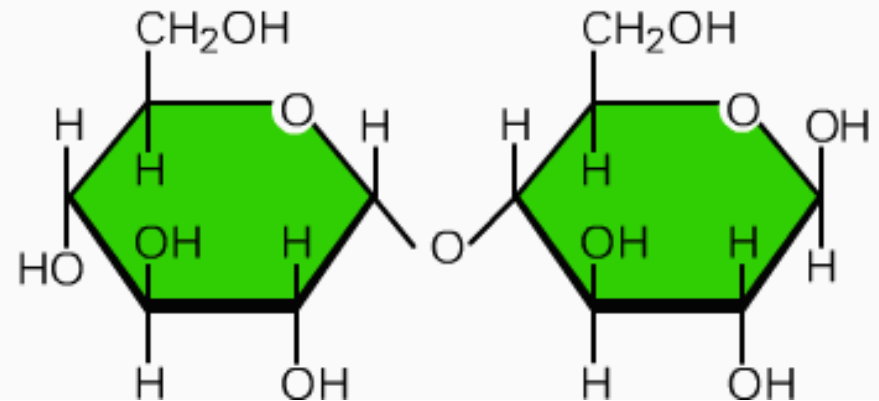

➤ Examples of disaccharide synthesis.

(a) Dehydration reaction in the synthesis of maltose.

The bonding of two glucose units forms maltose. The 1–4 glycosidic linkage joins the number 1 carbon of one glucose to the number 4 carbon of the second glucose. Joining the glucose monomers in a different way would result in a different disaccharide.

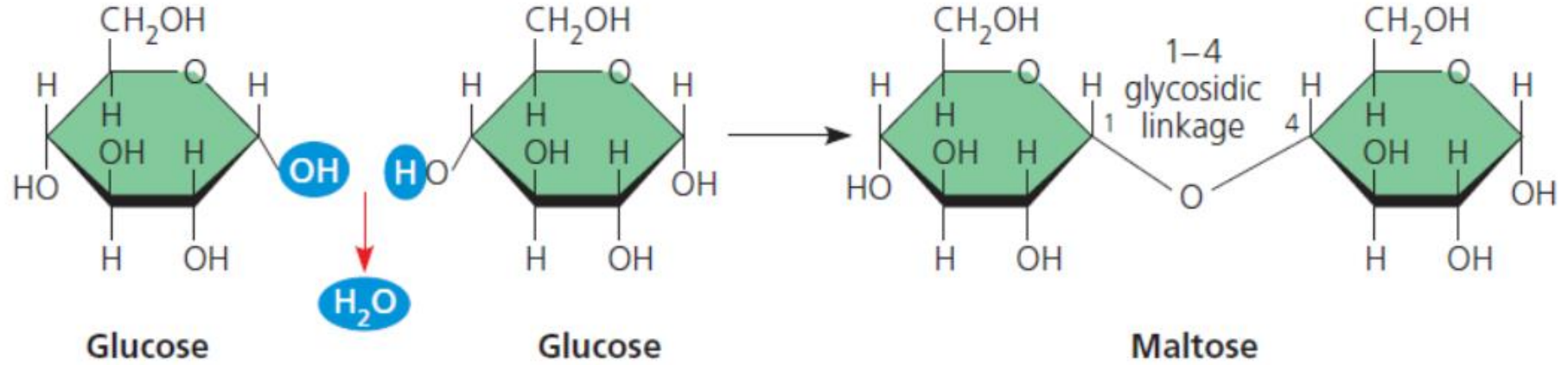

(b) Dehydration reaction in the synthesis of sucrose.

Sucrose is a disaccharide formed from glucose and fructose. Notice that fructose forms a five-sided ring, though it is a hexose like glucose.

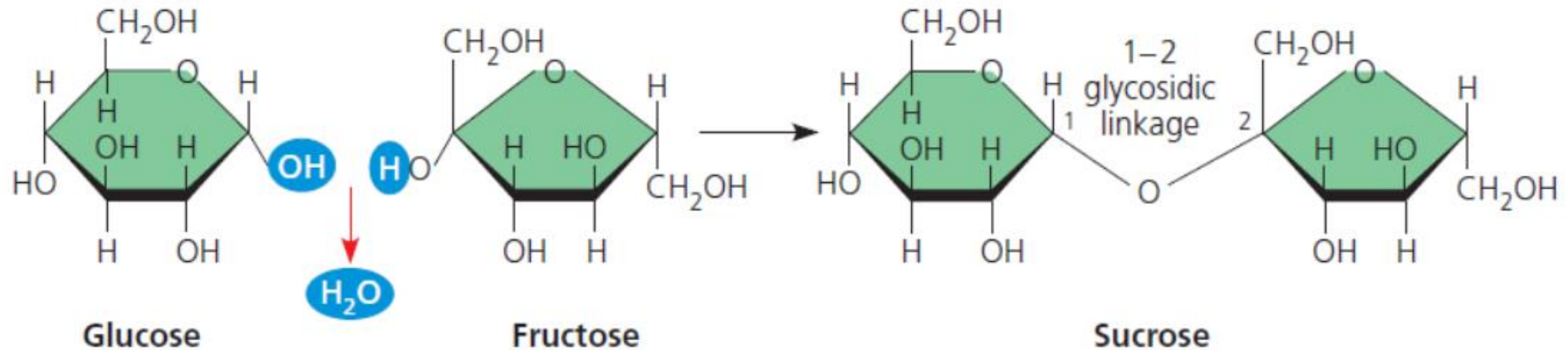

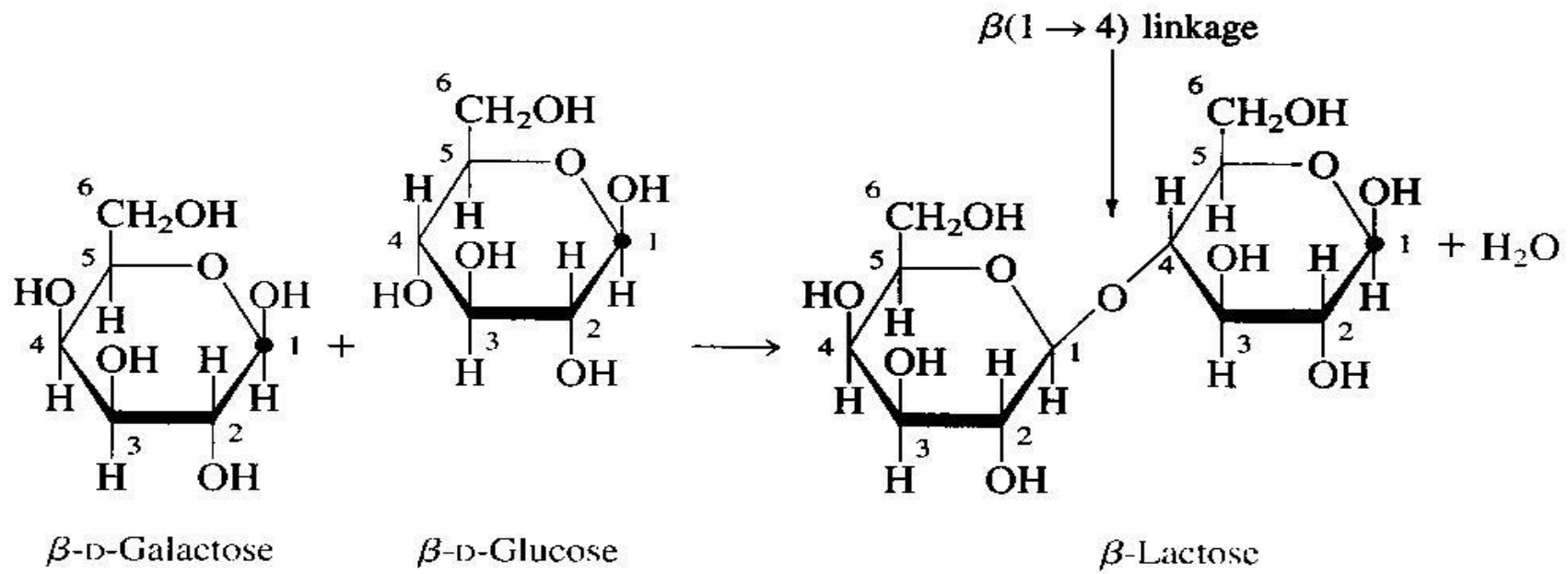

trisaccharide

แหล่งที่พบ

raffinose

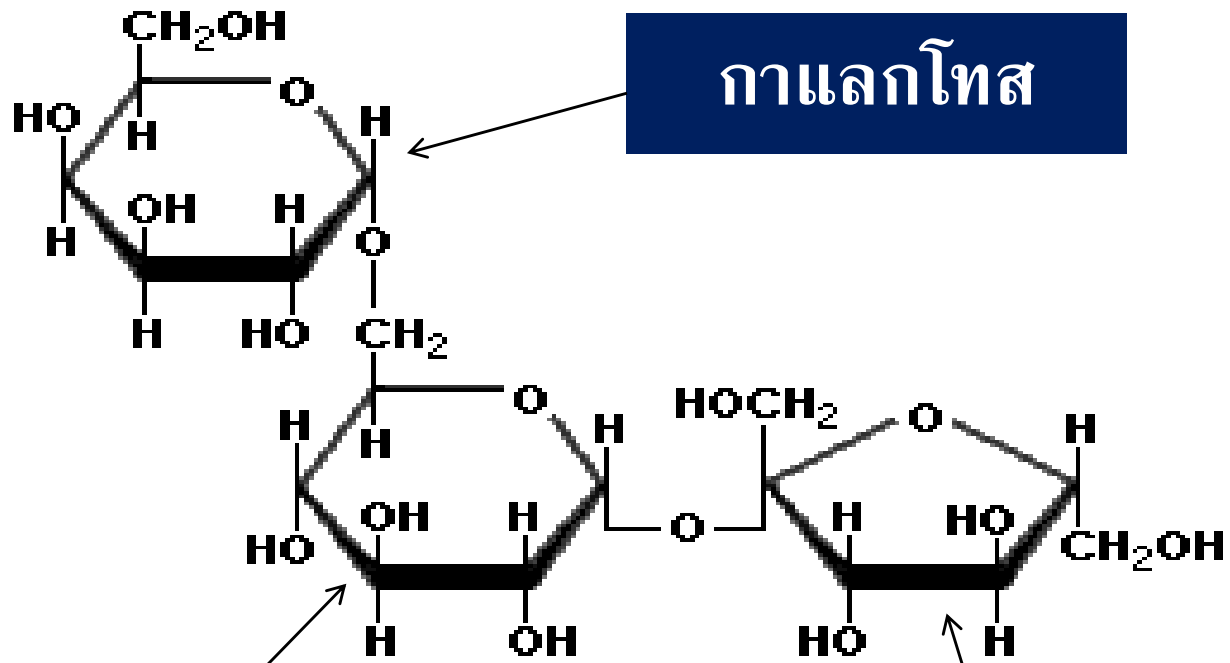

หัวบีทรูท (*Beta vulgaris* L.)



กลูโคส

ฟรุกโทส

Polysaccharide

Polysaccharides are macromolecules, polymers with a few hundred to a few thousand monosaccharides joined by glycosidic linkages.

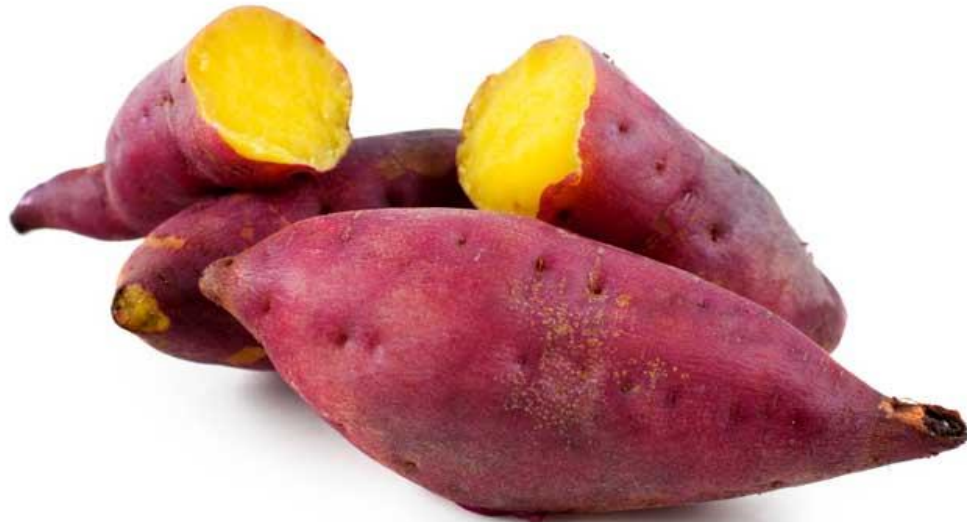

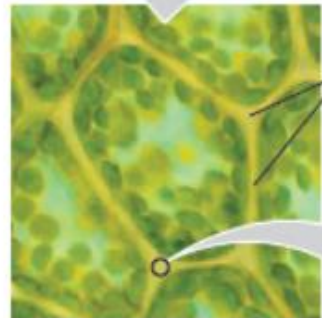
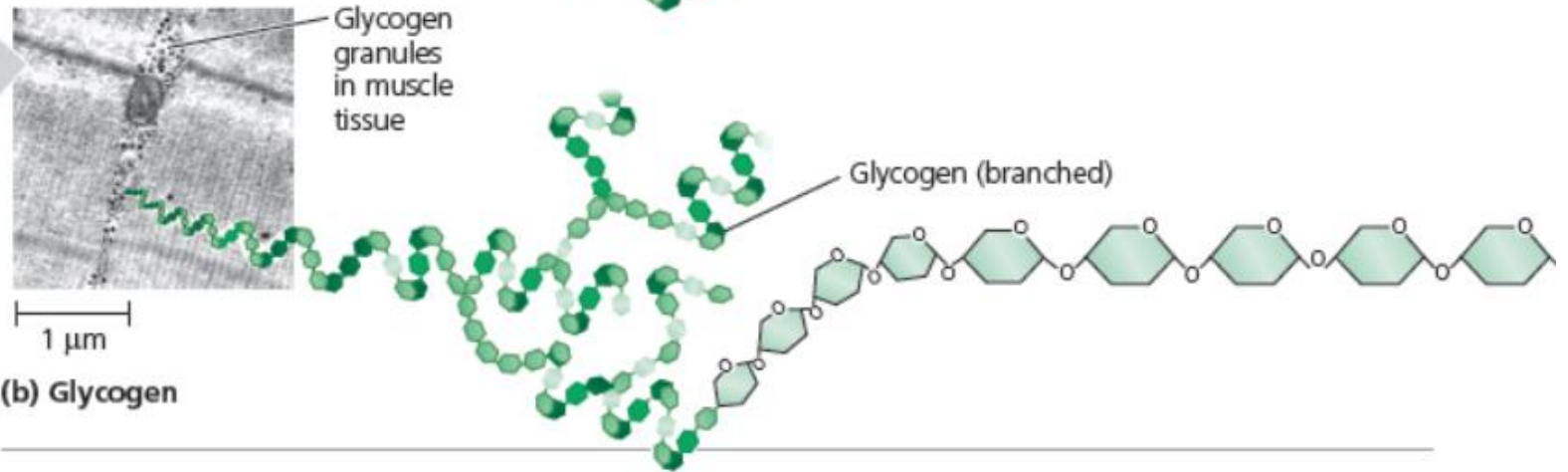
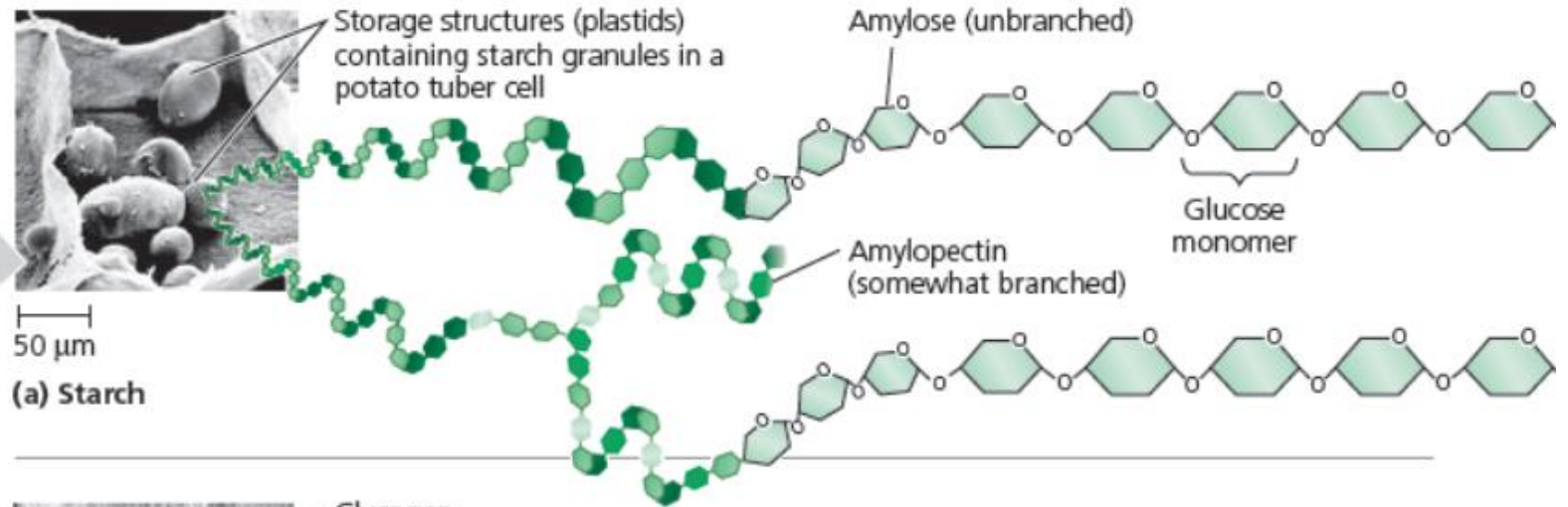

Plant cell, surrounded by cell wall

10 μm

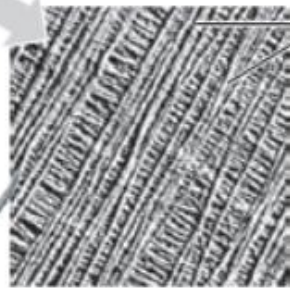

Cellulose microfibrils in a plant cell wall

Microfibril (bundle of about 80 cellulose molecules)

0.5 μm

(c) Cellulose

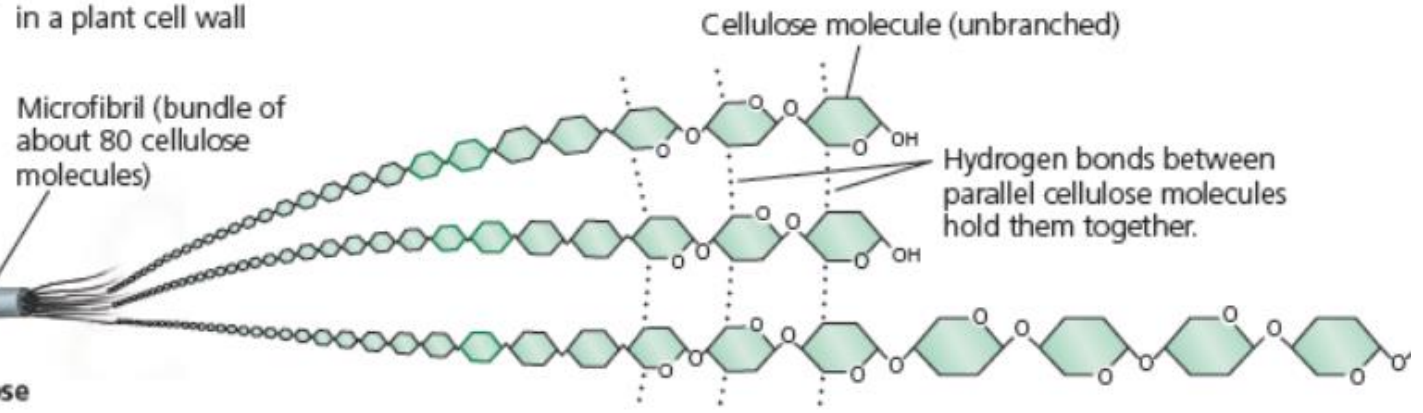

เปรียบเทียบ Glycogen & Amylopectin

Amylopectin

ข้อเหมือน

Glycogen

โครงสร้าง : โมเลกุลของกลูโคสเรียงตัว
ต่อกัน และมีการแตกแขนง

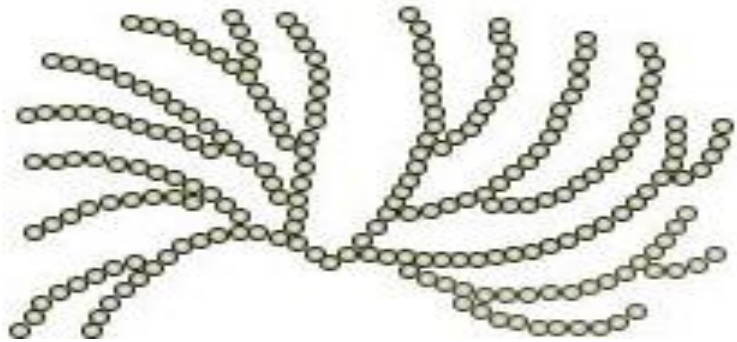

ข้อต่าง

มีขนาดเล็ก เพราะความถี่ในการแตกกิ่ง
น้อยกว่า (ทุก ๆ 20-24 หน่วย)

โครงสร้าง : โมเลกุลของกลูโคสเรียงตัว
ต่อกัน และมีการแตกแขนง

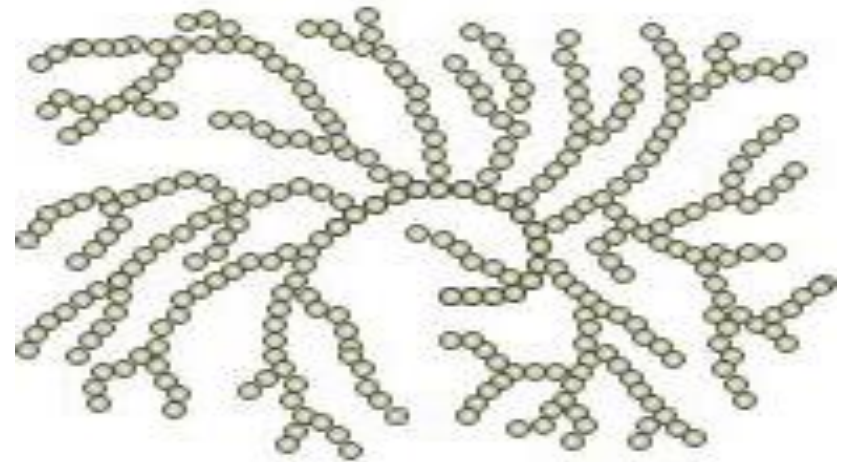

มีขนาดใหญ่ เพราะความถี่ในการแตกกิ่ง
มากกว่า (ทุก ๆ 8-12 หน่วย)

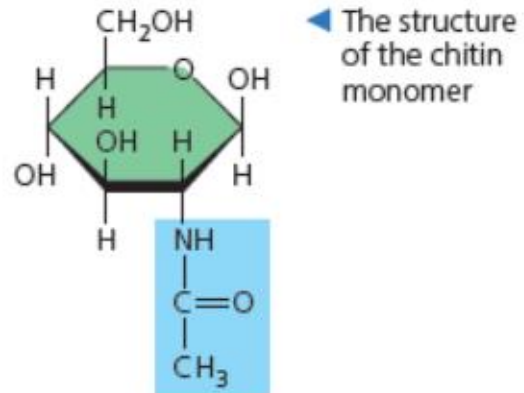

◀ Chitin, embedded in proteins, forms the exoskeleton of arthropods. This cicada is molting—shedding its old exoskeleton and emerging in adult form.

▶ Chitin is used to make a strong and flexible surgical thread that decomposes after the wound or incision heals.



▲ **Figure 5.8** Chitin, a structural polysaccharide.

ตารางที่ 2.12 ความหวานสัมพัทธ์ (relative sweetness) ของน้ำตาลและสารแทนน้ำตาล (sugar substitute)

ชนิดของน้ำตาล	ความหวานสัมพัทธ์	ชนิดของสารให้ความหวานสังเคราะห์	ความหวานสัมพัทธ์
แล็กโทส (น้ำตาลนม)	0.16	ไซคลาเมต (cyclamate)	30.00
มอลโทส (น้ำตาลมอลต์)	0.33	แอสพาร์แทม (aspartame)	150.00
กลูโคส (น้ำตาลในเลือด)	0.75	สเตเวียหรือหญ้าหวาน (stevia)	300.00
ซูโครส (น้ำตาลทราย)	1.00	แซ็กคาริน (saccharin)	350.00
ฟรุคโทส (น้ำตาลผลไม้)	1.75	ซูคราโลส (sucralose)	600.00

ที่มา: Enger, Ross and Bailey, 2009, หน้า 52

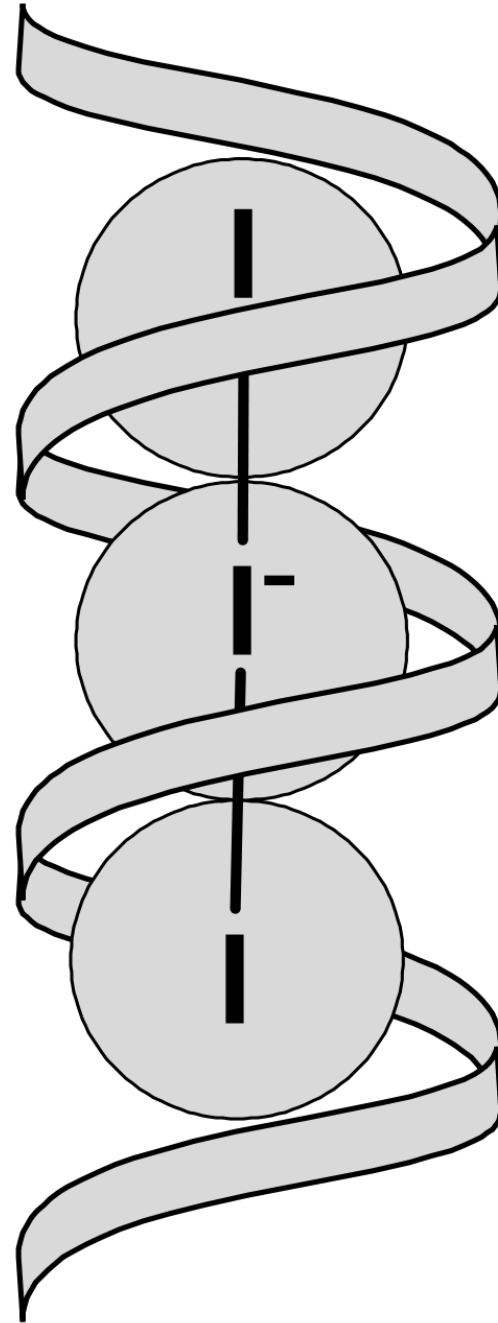

Amylosehelice with the
glucose-monomerunit:

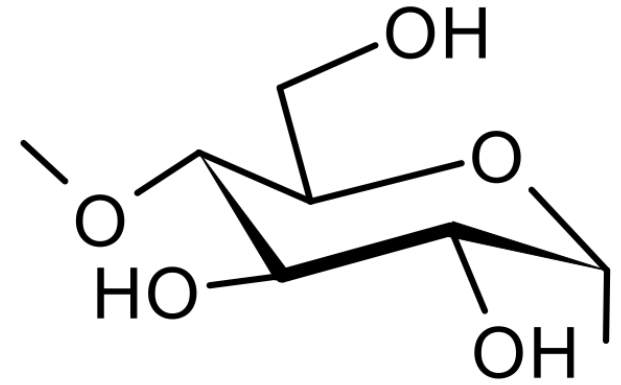

Tollens' reagent

Aldehydes ถูกออกซิไดซ์ได้ด้วยตัวออกซิไดซ์อย่างอ่อน เช่น

Tollens' reagent (silver ion in ammonia solution) โดยเห็นโลหะเงินจับที่ข้างหลอดคล้ายกระจกเงา เรียกว่า silver mirror

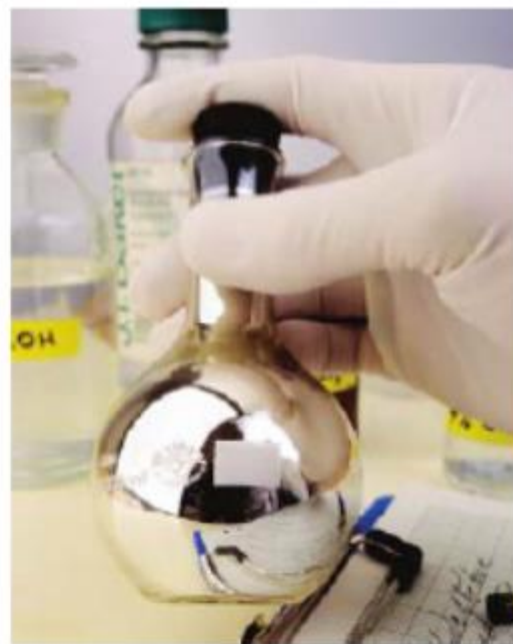
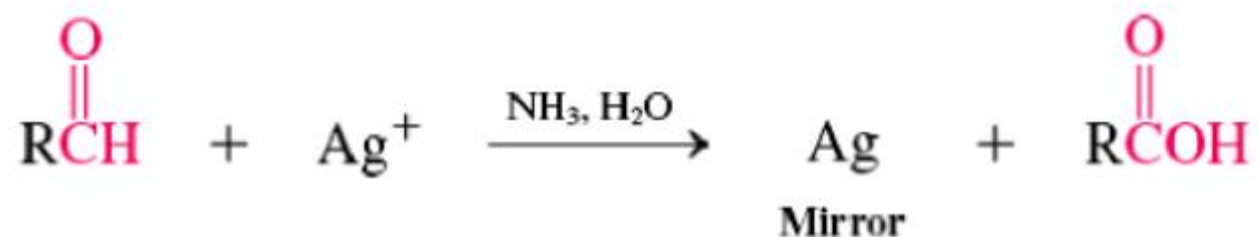

การทดสอบด้วยสารละลายเบเนดิกส์ (Benedict's test)

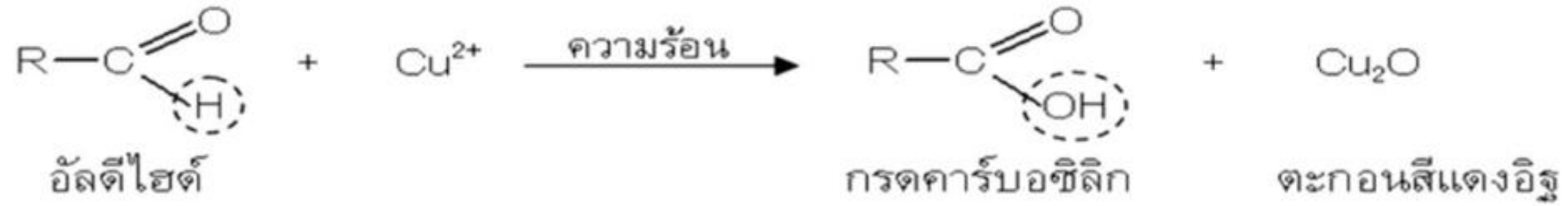

Benedict's test for sugars

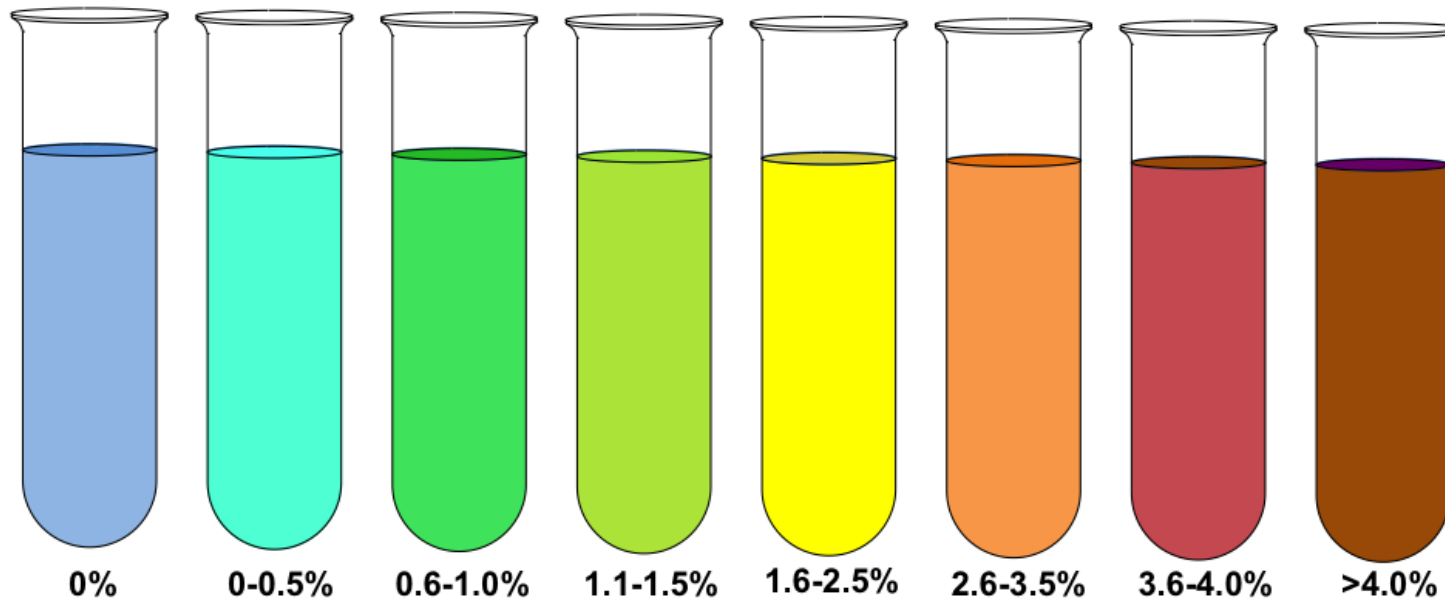

Fehling's solution

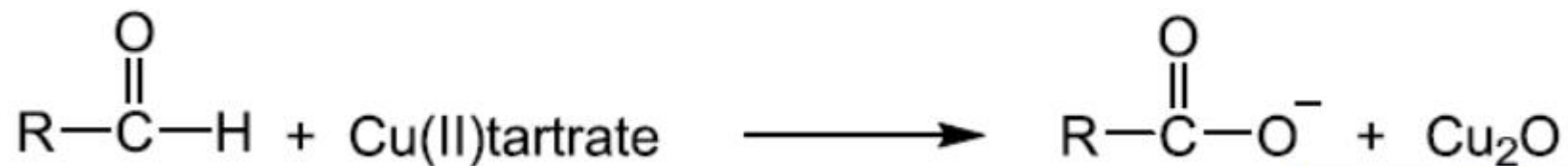
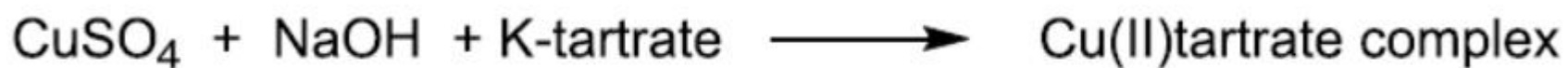

ตะกอนสีแดงอิฐ



Cu จะอยู่ในรูป Cu^{2+} เมื่อเกิดปฏิกิริยา
 Cu^{2+} จะถูกรีดิวซ์เป็น Cu^+

Lipids



- Although fats are not polymers, they are large molecules assembled from smaller molecules by dehydration reactions.
- A fat is constructed from two kinds of smaller

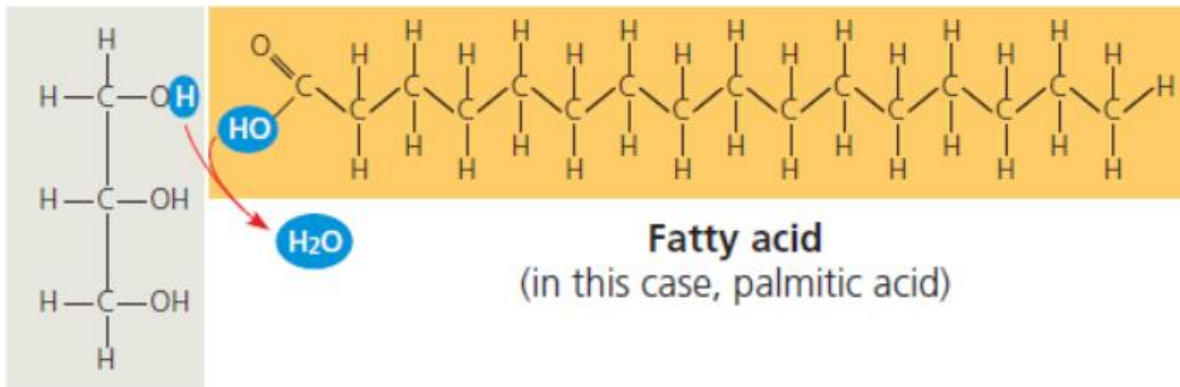

Glycerol

Fatty acid
(in this case, palmitic acid)

(a) One of three dehydration reactions in the synthesis of a fat

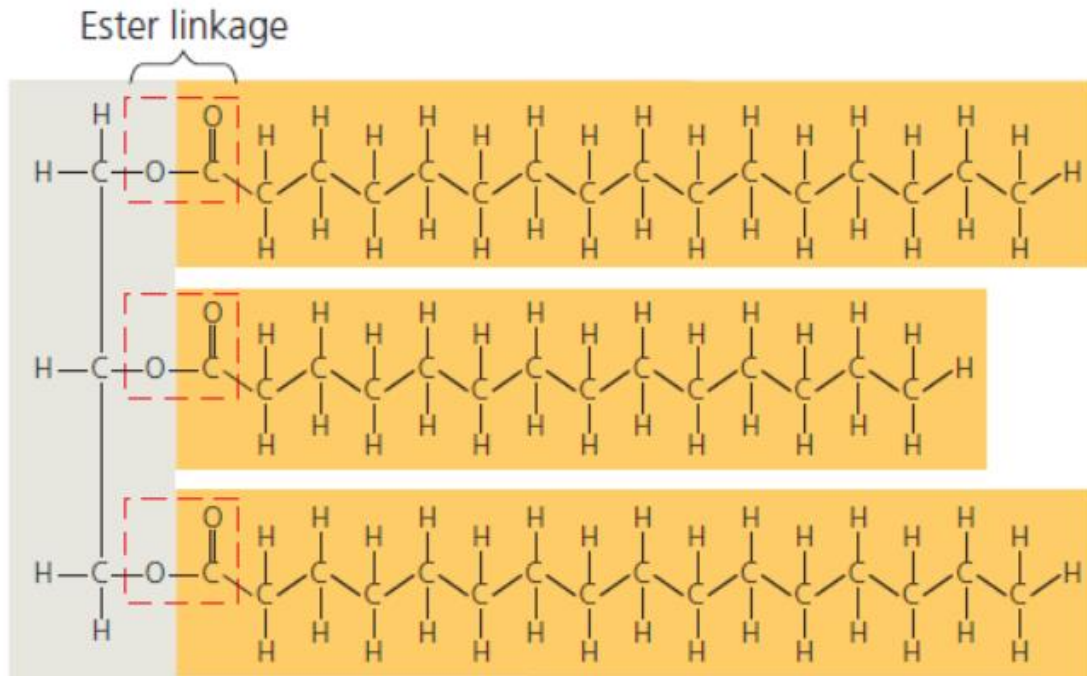

(b) Fat molecule (triacylglycerol)

- **Glycerol is an alcohol**; each of its three carbons bears a hydroxyl group.
- **A fatty acid** has a long carbon skeleton, usually 16 or 18 carbon

The terms **saturated fats** and **unsaturated fats** are commonly used in the context of nutrition.

(a) Saturated fat

At room temperature, the molecules of a saturated fat, such as the fat in butter, are packed closely together, forming a solid.



Structural formula of a saturated fat molecule (Each hydrocarbon chain is represented as a zigzag line, where each bend represents a carbon atom and hydrogens are not shown.)

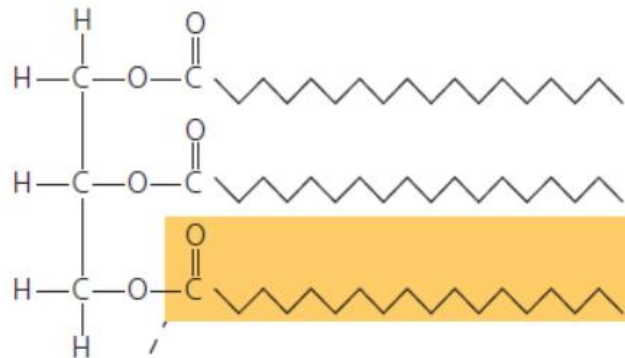

Space-filling model of stearic acid, a saturated fatty acid (red = oxygen, black = carbon, gray = hydrogen)

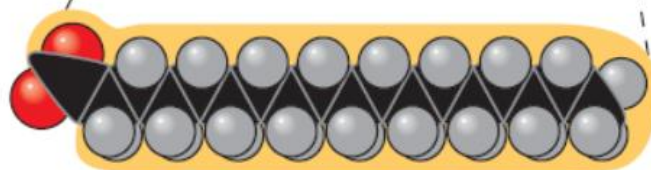

(b) Unsaturated fat

At room temperature, the molecules of an unsaturated fat such as olive oil cannot pack together closely enough to solidify because of the kinks in some of their fatty acid hydrocarbon chains.



Structural formula of an unsaturated fat molecule

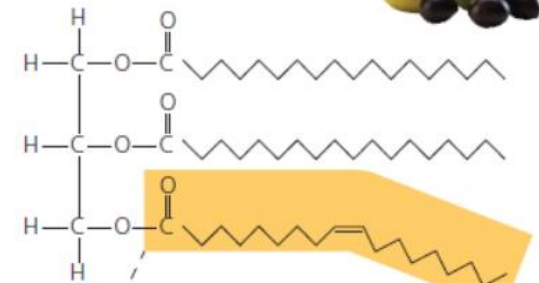

Space-filling model of oleic acid, an unsaturated fatty acid

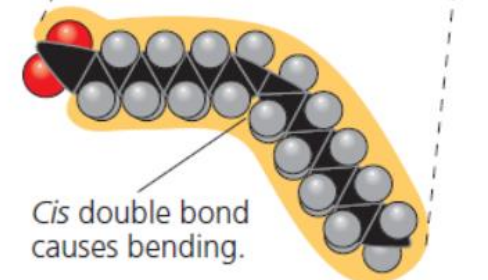

The phrase **“hydrogenated vegetable oils”** on food labels means that unsaturated fats have been synthetically converted to saturated fats by adding hydrogen.

- Peanut butter, margarine, and many other



Nutrition Facts		Amount/Serving	%DV*	Amount/Serving	%DV*	
Total Fat		7g	11%	Total Carb.	20g	7%
Serv. Size		4 cookies (32g)				
Servings		9				
Calories		150				
Calories from fat		60				
Sat. Fat		4.5g	23%	Dietary Fiber	1g	4%
Trans Fat		0g		Sugars	10g	
Cholest.		0mg	0%	Protein	2g	
Sodium		115mg	5%			
Vitamin A 0% • Vitamin C 0% • Calcium 0% • Iron 4%						
INGREDIENTS: Enriched flour, riboflavin, sugar, partially hydrogenated vegetable oil, cocoa, cornstarch, hydrogenated oils, soy lecithin, salt, caramel color, artificial flavors.						

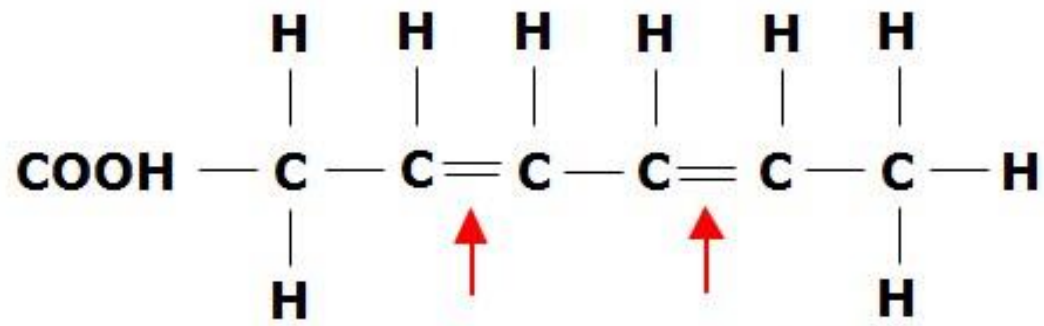

Polyunsaturated Fat

Hydrogenation

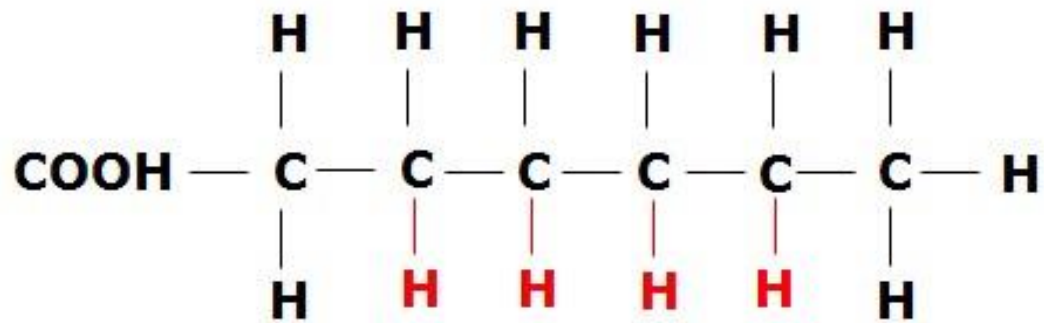

Hydrogenated Fat

Hydrogenation of Oleic Acid

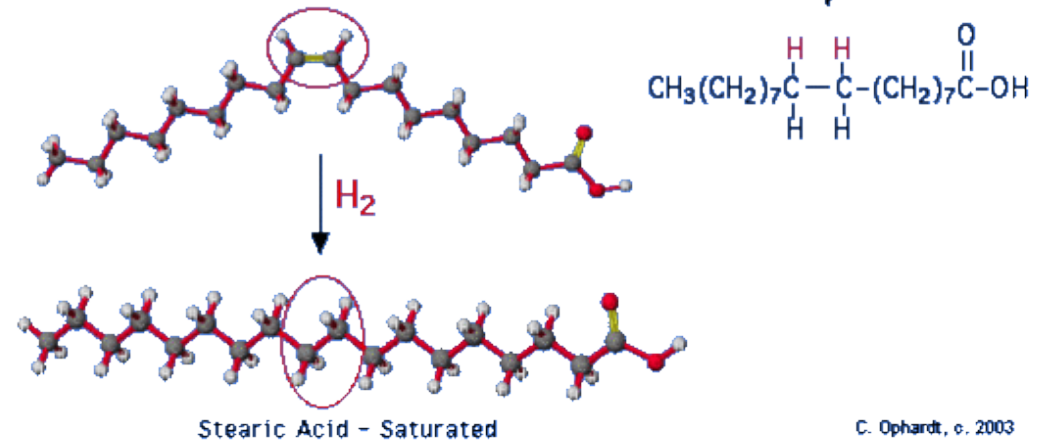
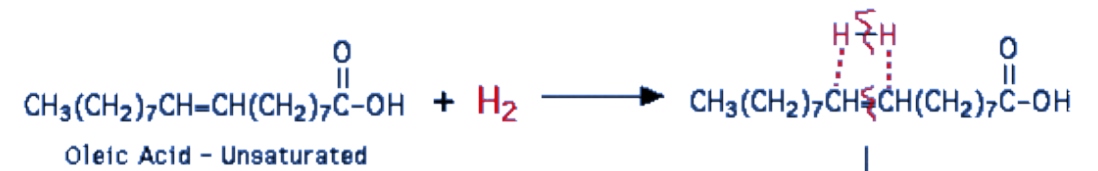

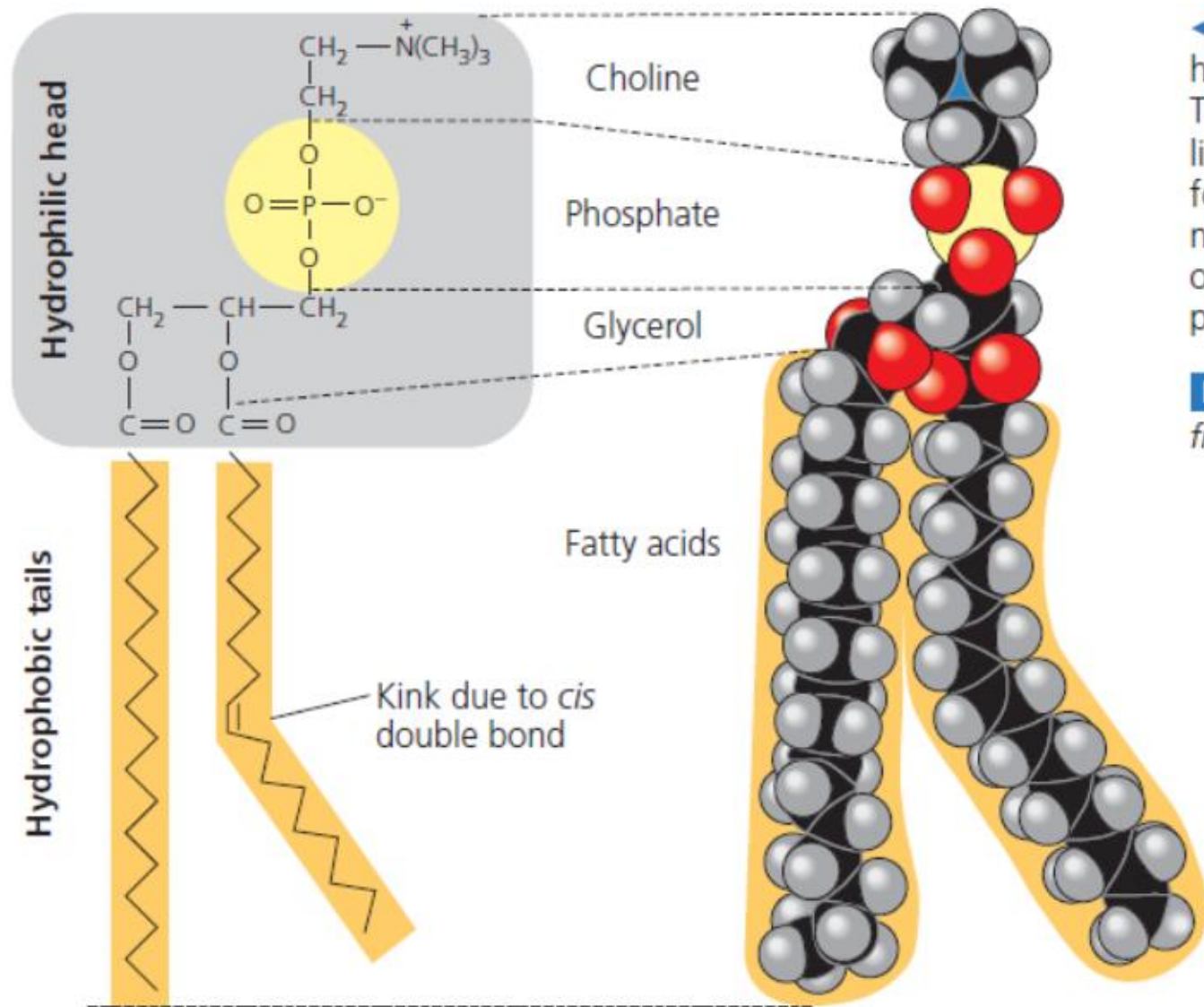

◀ **Figure 5.11 The structure of a phospholipid.** A phospholipid has a hydrophilic (polar) head and two hydrophobic (nonpolar) tails. This particular phospholipid, called a phosphatidylcholine, has a choline attached to a phosphate group. Shown here are (a) the structural formula, (b) the space-filling model (yellow = phosphorus, blue = nitrogen), (c) the symbol for a phospholipid that will appear throughout this book, and (d) the bilayer structure formed by self-assembly of phospholipids in an aqueous environment.

DRAW IT Draw an oval around the hydrophilic head of the space-filling model.

© Pearson Education, Inc.

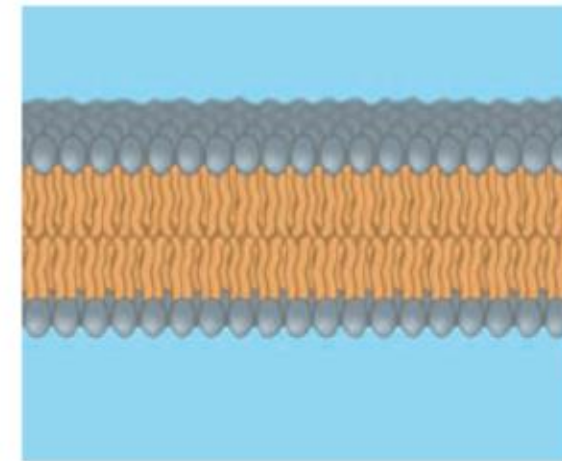
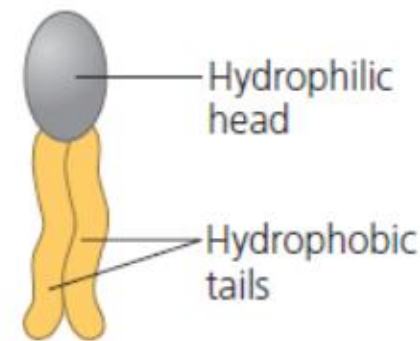

(a) Structural formula

(b) Space-filling model

(c) Phospholipid symbol

(d) Phospholipid bilayer

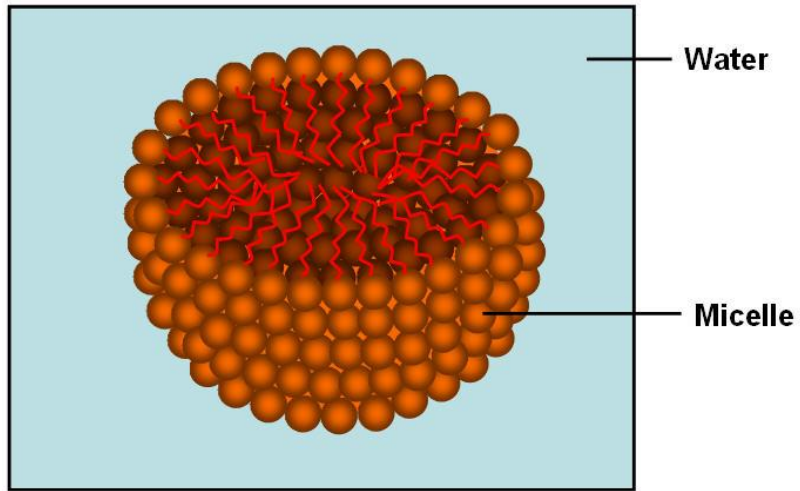

Above: a soap micelle with its top cut off – note the oil-like hydrocarbon non-polar tails aggregated in the centre and the polar heads on the outside facing the surrounding water.

Below: a slice through the same micelle.

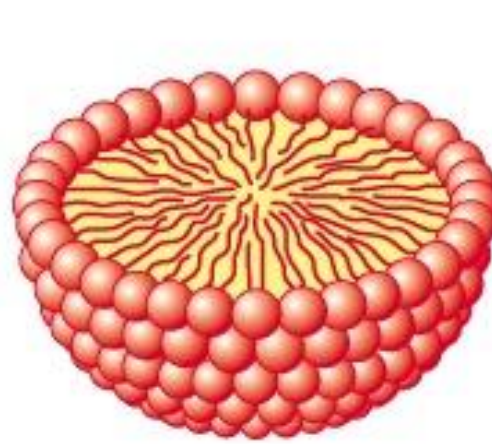
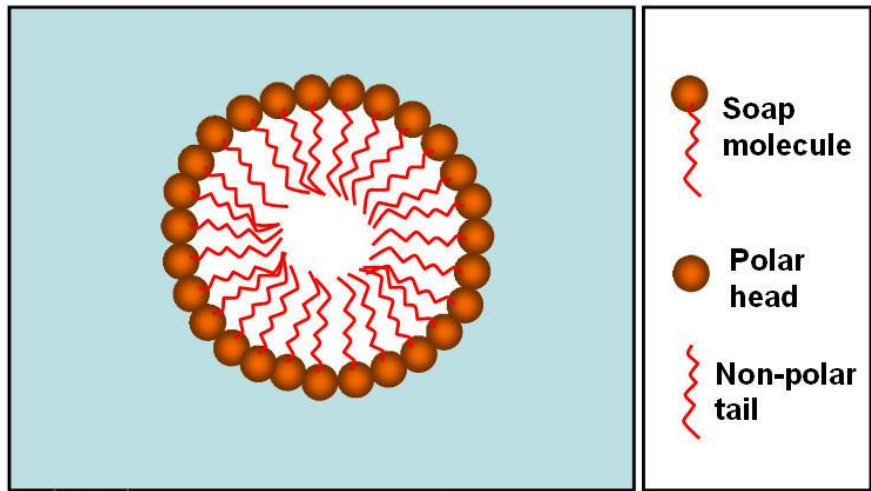

Micelle

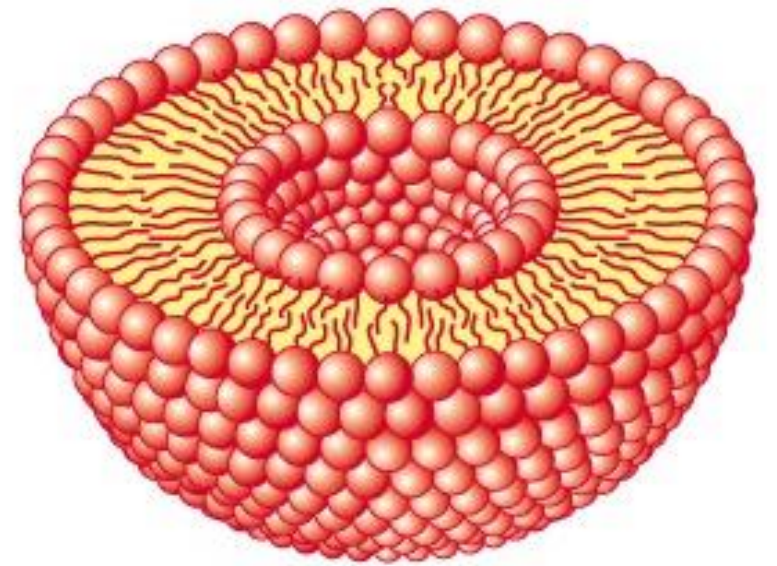

Liposome

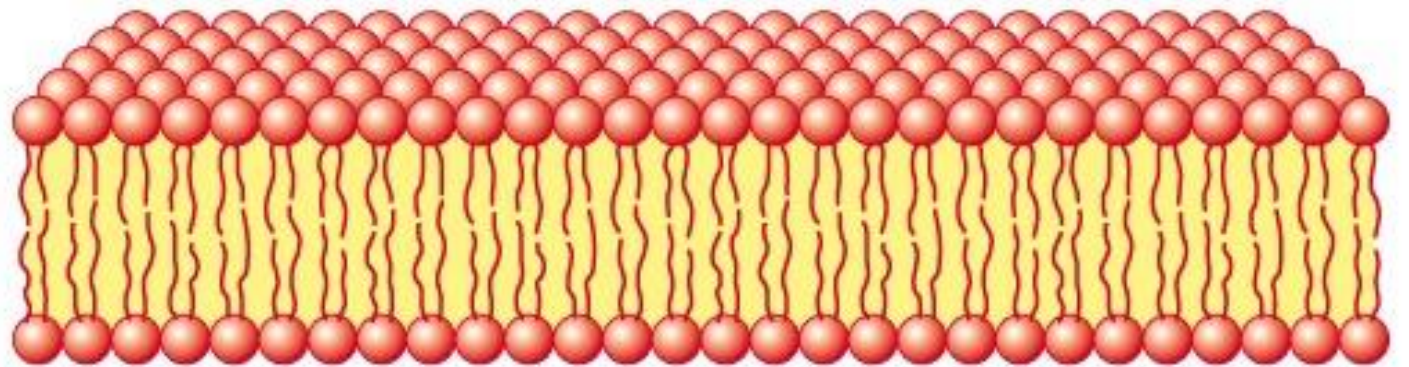

Bilayer sheet

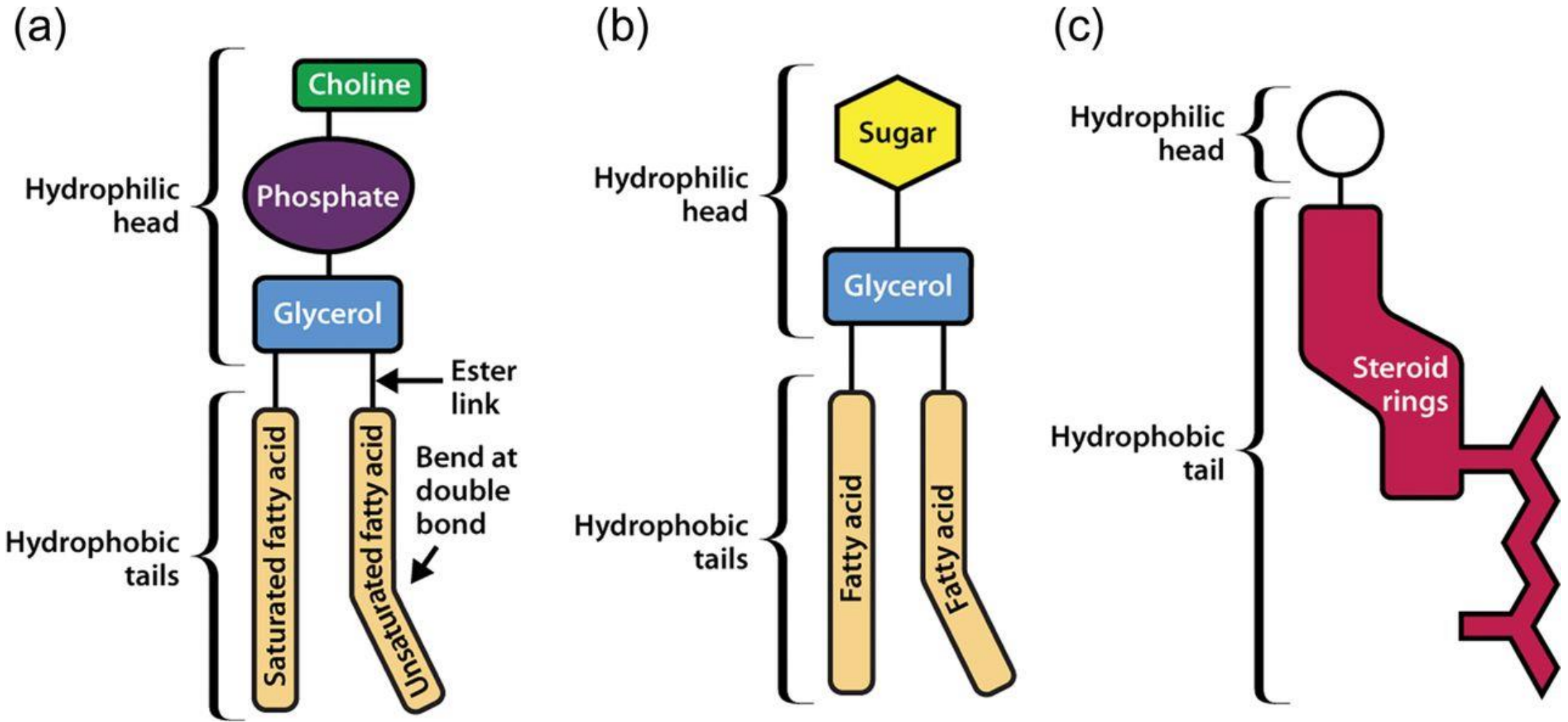

chematic representations of three types of membrane lipid.

(a) Phosphatidylcholine, a glycerophospholipid (b)

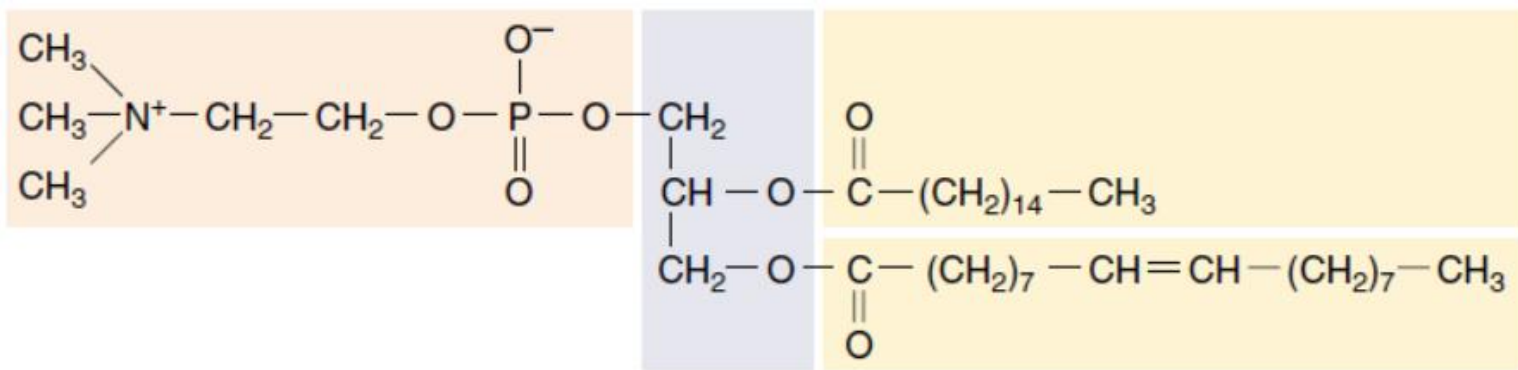

(a) Phospholipid (phosphatidyl choline)

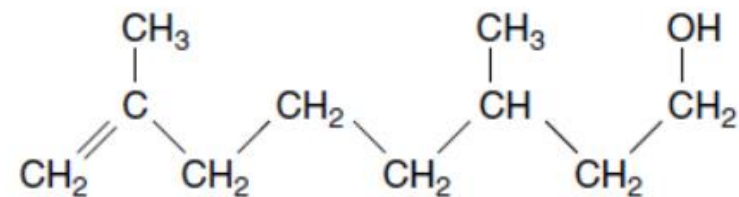

(c) Terpene (citronellol)

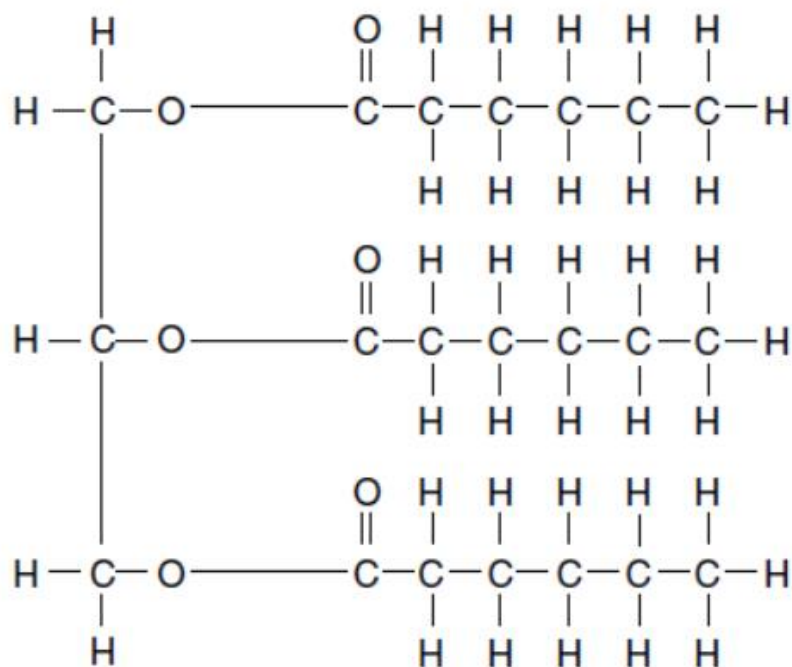

(b) Triacylglycerol molecule

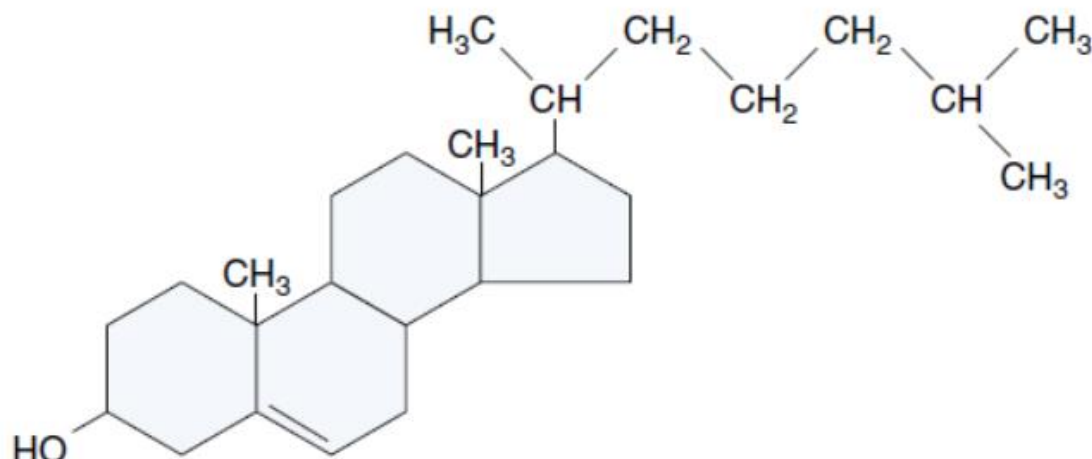

(d) Steroid (cholesterol)

FIGURE 3.19

Lipids. These structures represent four major classes of biologically important lipids: (a) phospholipids, (b) triacylglycerols (triglycerides), (c) terpenes, and (d) steroids.

Lipid (Steroids)

- Steroids
 - Are lipids characterized by a carbon skeleton consisting of four fused rings
 - Many hormones, including vertebrate sex hormones, are steroids produced from cholesterol
 - Steroids play a role in regulating cell activities

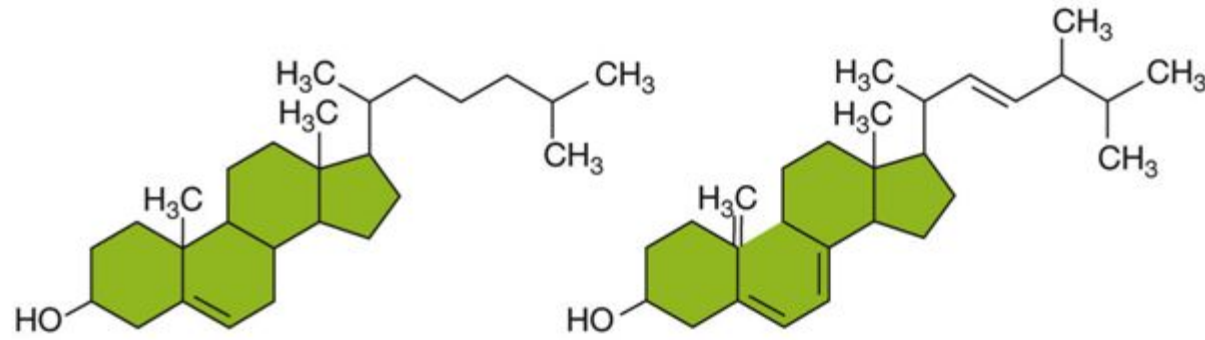

Cholesterol

Vitamin D₂

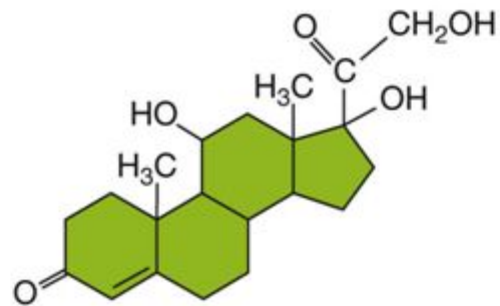



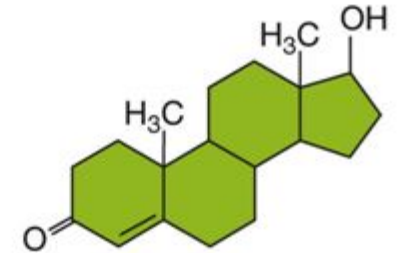

Cortisol



Testosterone

Cholesterol

Cholesterol is a waxy fat carried through the bloodstream by lipoproteins

-  **LDL:** low density lipoproteins, or "bad cholesterol"
-  **HDL:** high-density lipoproteins, or "good cholesterol"
-  **Triglycerides**
-  **Total cholesterol**

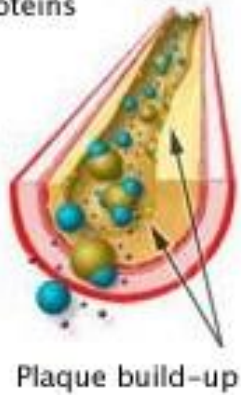

Cholesterol is produced by the liver and we consume it from meat and dairy products

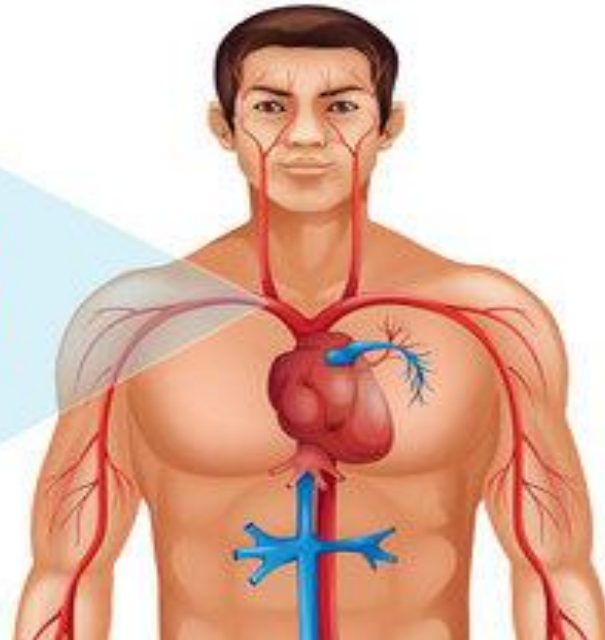
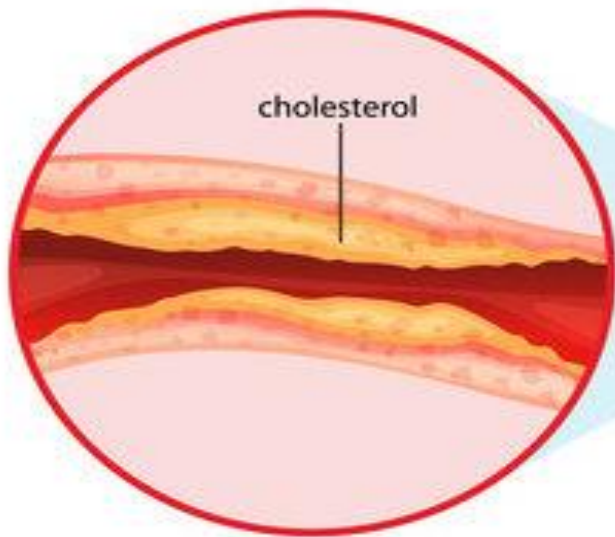
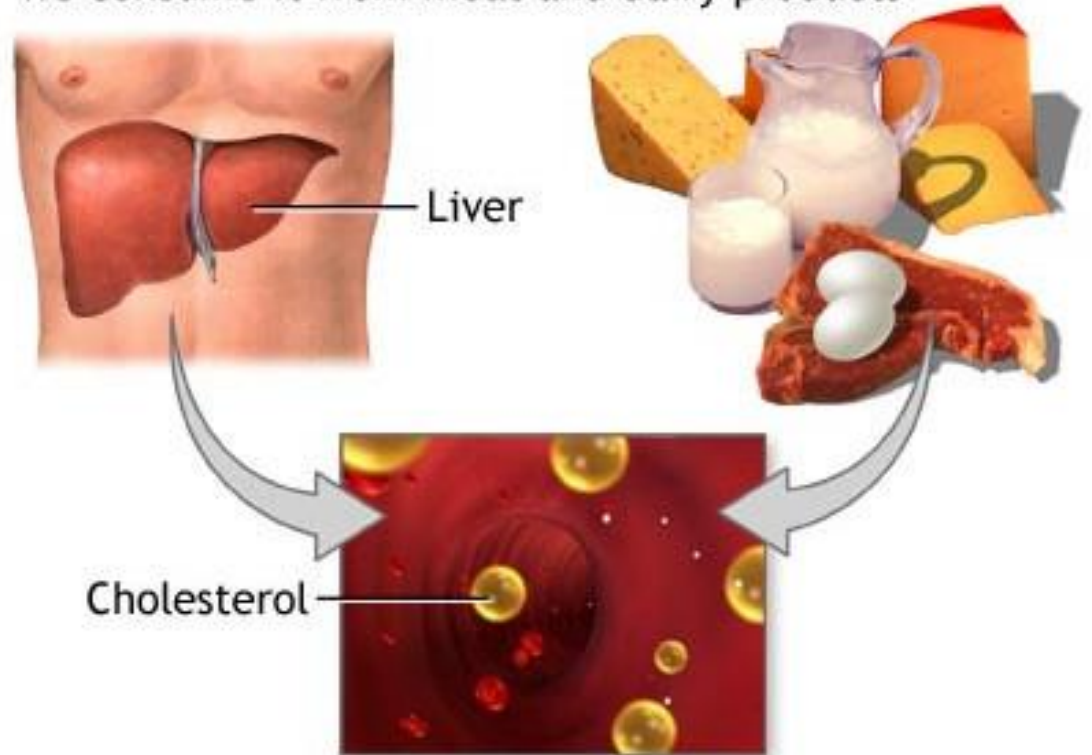

Hydrogenation of Oleic Acid

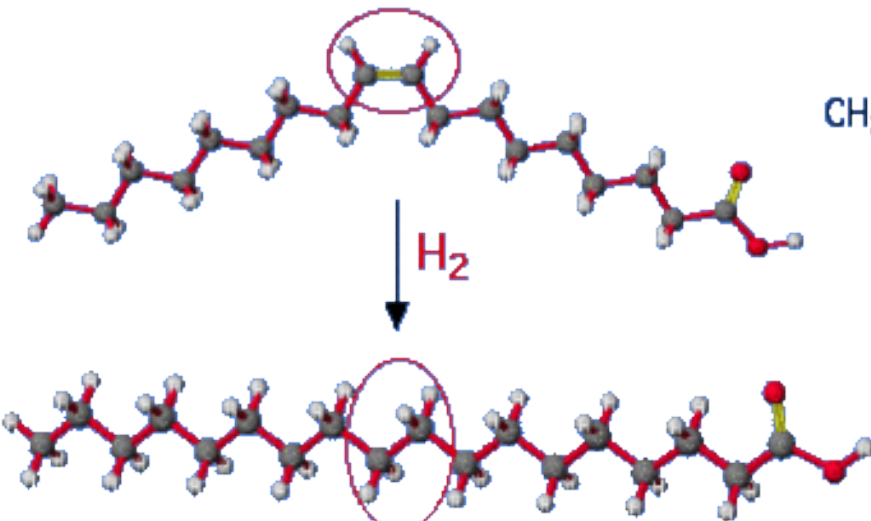
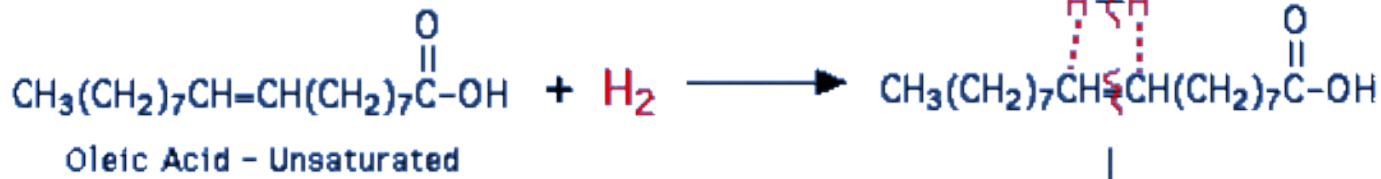

Stearic Acid - Saturated

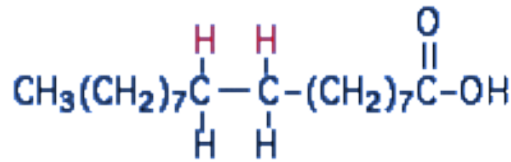

C. Ophardt, c. 2003

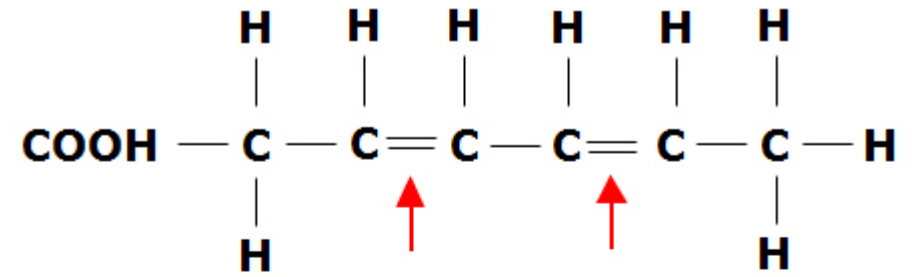

Polyunsaturated Fat

Hydrogenation

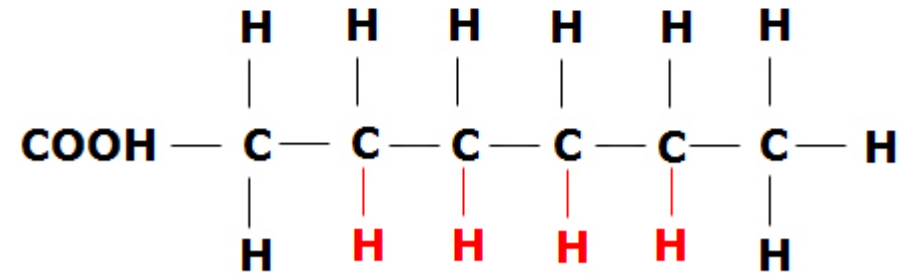

Hydrogenated Fat

